

# MORE SOLUTIONS TO STICKY PROBLEMS

**A Guide to Getting More From Your Brookfield Viscometer**

- Making Rheological Measurements

- Equipment for Specific Situations

- How the Brookfield Viscometer Works

- Viscosity Measurement Techniques

- Newtonian and non-Newtonian Fluids

- Temperature Dependence of Viscosity

and much more!

 **BROOKFIELD**

## MORE SOLUTIONS TO STICKY PROBLEMS: TABLE OF CONTENTS

<b>INTRODUCTION</b> .....	<b>1</b>	2.11 Defined Shear Stress .....	7
<b>CHAPTER 1</b> .....	<b>2</b>	2.12 Non-Flowing Sample Materials .....	8
1.1 Why Make Rheological Measurements? ....	2	2.12.1 Helipath Stand .....	8
1.2 Thinking Rheo-Logically .....	2	2.12.2 Spiral Adapter .....	8
1.3 Three Schools of Thought on Viscosity		2.12.3 Vane Spindles .....	8
Measurement .....	2	2.13 Special Accessory Items .....	8
1.3.1 The Pragmatic School .....	2	2.13.1 Quick Connect .....	8
1.3.2 The Theoretical School .....	2	2.13.2 Spindle Extensions .....	8
1.3.3 The Academic School .....	3	2.14 Fumes and Hazardous Locations .....	8
		2.14.1 Purge Fittings .....	8
		2.14.2 Explosion-Proof Construction .....	8
		2.15 Process Control .....	8
<b>CHAPTER 2</b> .....	<b>3</b>	<b>CHAPTER 3</b> .....	<b>9</b>
2.1 Equipment for Specific Situations .....	3	3.1 Why You Should Read This Chapter .....	9
2.2 Viscometers .....	3	3.2 How the Brookfield Viscometer Works .....	9
2.3 Rheometers .....	3	3.3 Spring Torque .....	10
2.4 Spindle Geometries .....	4	3.4 Viscosity Measurement Techniques .....	10
2.4.1 Disc Spindles .....	4	3.4.1 Record Keeping .....	10
2.4.2 Cylindrical Spindles .....	4	3.4.2 The Spindle and the Guardleg .....	10
2.4.3 Coaxial Cylinders .....	4	3.4.3 Selecting a Spindle Speed .....	10
2.4.4 Cone/Plate Geometry .....	4	3.4.4 Sample Container Size .....	11
2.4.5 T-Bar Spindles .....	4	3.4.5 Sample Conditions .....	11
2.4.6 Vane Spindles .....	5	3.4.6 Spindle Immersion .....	11
2.5 Temperature Control .....	5	3.4.7 Sensitivity and Accuracy .....	11
2.5.1 Temperature Baths .....	5	3.4.8 Obtaining a Viscometer Reading .....	11
2.5.2 Thermosel System .....	5	3.4.9 A Calibration Check .....	12
2.5.3 Peltier (Thermo-electric Systems) .....	5	3.4.10 Recalibrating the Brookfield	
2.6 Small Sample Volume .....	5	Viscometer .....	12
2.6.1 Small Sample Adapter .....	5	3.5 Viscometer Maintenance .....	13
2.6.2 UL Adapter .....	5	3.6 Viscometer Troubleshooting .....	14
2.6.3 DIN Adapter .....	5		
2.6.4 Thermosel System .....	5		
2.6.5 Cone/Plate Systems .....	5		
2.7 Low Viscosity .....	5		
2.7.1 UL Adapter .....	6	<b>CHAPTER 4</b> .....	<b>14</b>
2.7.2 Small Sample Adapter .....	6	4.1 Coming to Grips with Rheology .....	14
2.7.3 Thermosel System .....	6	4.2 Viscosity .....	14
2.7.4 Wells-Brookfield Cone/Plate Viscom-		4.3 Newtonian Fluids .....	15
eter .....	6	4.4 Non-Newtonian Fluids .....	15
2.8 High Temperature .....	6	4.5 Thixotropy and Rheopexy .....	16
2.8.1 Thermosel System .....	6	4.6 Laminar and Turbulent Flow .....	17
2.8.2 Temperature Baths .....	6	4.7 Yield Behavior .....	17
2.8.3 Cone/Plate with		4.8 What Affects the Rheological Property? ...	18
Embedded Heating .....	6	4.8.1 Temperature .....	18
2.9 Defined Shear Rate .....	6	4.8.2 Shear Rate .....	18
2.10 High Shear Rate .....	7	4.8.3 Measuring Conditions .....	19
2.10.1 Wells-Brookfield Cone/Plate Viscom-		4.8.4 Time .....	19
eter/Rheometer .....	7	4.8.5 Pressure .....	19
2.10.2 CAP Viscometer/Rheometer .....	7	4.8.6 Previous History .....	20
2.10.3 R/S Rheometer .....	7	4.8.7 Composition and Additives .....	20
2.10.4 PVS Rheometer .....	7	4.8.8 Special Characteristics of Dispersions	
		and Emulsions .....	20

<b>CHAPTER 5 .....</b>	<b>21</b>
5.1 Advanced Methods for Rheological Analysis .....	21
5.2 Defining Operating Parameters of Various Spindle Geometries .....	21
5.2.1 Cylindrical Spindles .....	21
5.2.2 Coaxial Cylinders .....	22
5.2.3 Cone and Plate .....	22
5.2.4 Disc and T-Bar Spindles .....	22
5.2.5 Spiral Adapter Spindle .....	22
5.2.6 "Paddle" / "Paste" Spindles .....	23
5.2.7 Vane Spindles .....	23
5.2.8 Other Special Spindles .....	23
5.3 Analyzing Time-Independent Non-Newtonian Fluids .....	23
5.3.1 Ratio Methods .....	23
5.3.2 Graphic Methods .....	23
5.3.3 Template Method .....	24
5.3.4 Dynamic Yield Value Determination .....	24
5.4 Static Yield Value Determination .....	25
5.5 Analyzing Time-Dependent, Non-Newtonian Fluids .....	25
5.6 Temperature Dependence of Viscosity .....	25
5.7 Math Models .....	26
5.8 Brookfield Application Software .....	26
5.9 Miscellaneous Methods .....	27

<b>CHAPTER 6 .....</b>	<b>27</b>
6.1 Single Point Viscosity Test .....	27
6.2 Controlled Rate Ramp .....	27
6.3 Up-Down Rate Ramp .....	27
6.4 Time Sensitivity Test .....	27
6.5 Temperature Sensitivity Test .....	28
6.6 Temperature Profiling with Up-Down Rate .....	28
6.7 Static Yield Test .....	28
6.8 Dynamic Yield Test .....	28
6.9 Recovery .....	29

<b>APPENDIX A: Specifications, Ranges, and Operating Parameters .....</b>	<b>30</b>
A.1 Dial-Reading Viscometer Spindles and Speeds .....	31
A.2 Digital Viscometers/Rheometers Spindles and Speeds .....	32
A.3 Disc Spindle Information for Standard Viscometers/Rheometers .....	32
A.4 Cylindrical Spindles for Dial-Reading Viscometer and Digital Viscometers/Rheometers .....	33
A.5 Wells-Brookfield Cone/Plate Viscometers/Rheometers .....	35
A.6 Small Sample Adapter .....	36
A.7 UL Adapter .....	38
A.8 Thermoel System .....	39
A.9 DIN Adapter .....	40
A.10 Helipath Stand with T-Bar Spindles .....	41
A.11 Spiral Adapter .....	42
A.12 Vane Spindles .....	43
A.13 KU-2 (Krebs) Viscometer .....	44
A.14 YR-1 Yield Stress Rheometer .....	45
A.15 CAP 1000+ Viscometer .....	46
A.16 CAP 2000+ Viscometer .....	47
A.17 R/S Rheometer & R/S Soft Solids Tester .....	48
A.18 PVS Rheometer .....	49

<b>APPENDIX B: Spindle Entry Codes and Range Coefficients .....</b>	<b>51</b>
<b>APPENDIX C: ASTM Specifications .....</b>	<b>53</b>
<b>APPENDIX D: References .....</b>	<b>54</b>
<b>APPENDIX E: Brookfield Locations .....</b>	<b>55</b>

## INTRODUCTION

When a piece of technical equipment is marketed successfully for over 70 years, it is inevitable that a large body of experience will develop from the use of that equipment. Procedures are established, papers are published, standards are accepted, and a vast informal grapevine of advice grows amidst the community of users. Such is the case with the Brookfield Viscometer. Accepted as a standard of viscosity measurement around the world, the Brookfield Viscometer is the nucleus of a library of information that encompasses the experiences of thousands of users in a seemingly endless variety of applications.

This library, however, is not gathered conveniently together in any single location. It is fragmented, scattered here and there in technical journals, in test reports, in the notes made by technicians, researchers, and quality control people. For many users (particularly those new to the field of viscosity measurement), it is extremely difficult to gain access to information generated outside their own company or industry. Brookfield Engineering Laboratories has for many years acted as a clearinghouse for this type information, reprinting a variety of technical papers on the subject of viscosity measurement and making them available at no cost. This program has helped many people benefit from the experiences of others.

There is a middle ground, however, between the specific technical information provided in these papers and the basic operating procedures outlined in an instruction manual for your instrument. We have been requested many times over the years to publish a book that would bridge the gap between the elementary and the advanced, a sort of extended "user's manual" that would guide the way for the person wishing to explore in greater depth the field of viscosity measurement,

with an emphasis on Brookfield equipment.

The book you hold in your hand is the result of those requests. It does not replace your instruction manual, nor does it replace the specific technical papers already or yet to be published. It is also not a textbook on rheology. Rather, it is a guide to help point out the way to getting more from your Brookfield Viscometer. It does this in several ways:

- ◆ by offering practical advice on the use and maintenance of the Brookfield Viscometer based on our experience and that of our customers;
- ◆ by suggesting ways in which specific pieces of hardware may be used to solve viscosity measurement problems;
- ◆ by explaining the basic principles of rheology and their relation to measurements made with Brookfield equipment;
- ◆ by discussing factors that affect rheological behavior and how these may be controlled;
- ◆ by outlining advanced mathematical procedures for detailed analysis of viscosity data;
- ◆ by consolidating a variety of useful range tables, formulas, and specifications for many Brookfield Viscometers and accessories.

We hope that you will find this book useful and refer to it often. It is our attempt to answer all at once many of the questions we have been asked over the years. If you have any questions that are not answered here, or if you want to suggest improvements or changes for future editions, please feel free to contact us. It was, after all, the input of people like yourself that made this book possible in the first place.

# CHAPTER 1

## 1.1 Why Make Rheological Measurements?

Anyone beginning the process of learning to think Rheo-Logically must first ask the question, "Why should I make a viscosity measurement?" The answer lies in the experiences of thousands of people who have made such measurements, showing that much useful behavioral and predictive information for various products can be obtained, as well as knowledge of the effects of processing, formulation changes, aging phenomena, etc.

A frequent reason for the measurement of rheological properties can be found in the area of quality control, where raw materials must be consistent from batch to batch. For this purpose, flow behavior is an indirect measure of product consistency and quality.

Another reason for making flow behavior studies is that a direct assessment of processability can be obtained. For example, a high viscosity liquid requires more power to pump than a low viscosity one. Knowing rheological behavior, therefore, is useful when designing pumping and piping systems.

It has been suggested that rheology is the most sensitive method for material characterization because flow behavior is responsive to properties such as molecular weight and molecular weight distribution. This relationship is useful in polymer synthesis, for example, because it allows relative differences to be seen without making molecular weight measurements. Rheological measurements are also useful in following the course of a chemical reaction. Such measurements can be employed as a quality check during production or to monitor and/or control a process. Rheological measurements allow the study of chemical, mechanical, and thermal treatments, the effects of additives, or the course of a curing reaction. They are also a way to predict and control a host of product properties, end use performance and material behavior.

## 1.2 Thinking Rheo-Logically

To begin, consider the question, "Can some rheological parameter be employed to correlate with an aspect of the product or process?" To determine this, an instinct must be developed for the kinds of chemical and physical phenomena which affect the rheological response. For the moment, assume this information is known and several possibilities have been identified. The next step is to gather preliminary rheological data to determine what type of flow behavior is characteristic of the system under consideration. At the most basic level, this involves making measurements with whichever Brookfield Viscometer is available and drawing some conclusions based on the descriptions of flow behavior types in Chapter 4.

Once the type of flow behavior has been identified, more can be understood about the way components

of the system interact (more information on what affects the rheological property can be found in Section 4.7). The data thus obtained may then be fitted to one of the mathematical models which have been successfully used with Brookfield instruments. Many of these models may be found in Chapter 5.

Such mathematical models range from the very simple to the very complex. Some of them merely involve the plotting of data on graph paper; others require calculating the ratio of two numbers. Some are quite sophisticated and require use of programmable calculators or computers. This kind of analysis is the best way for getting the most from our data and often results in one of two "constants" which summarize the data and can be related to product or process performance.

Once a correlation has been developed between rheological data and product behavior, the procedure can then be reversed and rheological data may be used to predict performance and behavior.

## 1.3 Three Schools of Thought on Viscosity Measurement

In our experience there are basically three schools of thought on the use of viscometers in applications rheology. We present them here and invite you to decide which you fall into, remembering that there is no "right" one and that each has its merits.

### 1.3.1 The Pragmatic School

The first school of thought is the most pragmatic. The person who adheres to this school cares only that the Brookfield Viscometer generates numbers that tell something useful about a product or process. This person has little or no concern about rheological theory and measurement parameters expressed in absolute terms. Quality control and plant production applications are typical of this category.

### 1.3.2 The "Theoretical" School

The second school of thought involves a more theoretical approach. Those adhering to this school know that some types of Brookfield Viscometers will not directly yield defined shear rates and absolute viscosities for non-Newtonian fluids. However, these people often find that they can develop correlations of "dial viscosity" with important product or process parameters. Many people follow this school of thought. The applications rheology literature is replete with statements along the line of "I know the data isn't academically defined, but I keep this fact in mind and treat the multi-point rheology information as if it were." In many cases, this produces eminently satisfying results and eliminates the necessity of buying a highly sophisticated and very expensive piece of rheological equipment.

### 1.3.3 The Academic School

The third school of thought is quite academic in nature. People adhering to this school require that all measurement parameters, particularly shear rate and shear stress, be defined and known. They need equipment with defined geometries such as cone and plate or coaxial cylinders. Examples from the Brookfield line would be the Wells-Brookfield Cone/Plate and CAP Viscometers and the UL adapter, Small Sample Adapter, Thermosel, Din Adapter and Spiral Adapter accessories, as well as the R/S and

PVS Rheometers. With this equipment the shear rate is defined and accurate absolute viscosities are obtained directly.

That, then, is our view of the three schools of thought on viscosity measurement. You may need to think in terms of any or all of these depending on your background, approach, goals, and type of equipment available. Brookfield Viscometer users fall into all three; the following chapters present information of use to each.

## CHAPTER 2

### 2.1 Equipment for Specific Situations

The purpose of this chapter is to provide an overview of Brookfield's entire line of Viscometers, Rheometers and related accessories, and to suggest ways in which these products may be helpful in solving specific viscosity measurement problems. This information will be useful to people adhering to all three schools of thought on viscosity measurement.

The equipment has been organized into functional groups to help you quickly zero in on the items of most interest to you:

- Viscometers
- Rheometers
- Spindle Geometries
- Temperature Control
- Small Sample Volume
- Low Viscosity
- High Temperature
- Defined Shear Rate
- High Shear Rate
- Defined Shear Stress
- Non-Flowing Sample Materials
- Special Accessory Items
- Fumes and Hazardous Locations
- Process Control

### 2.2 Viscometers

Brookfield laboratory Viscometers are available in three basic types: dial-reading (analog), digital, and programmable. The most significant difference between them is the manner in which the viscosity reading is displayed. The dial-reading type is read by noting the position of a pointer in relation to a rotating dial; the Digital type is read by means of a 2-line LCD display. In addition, the Digital Viscometer includes a 0-10mv output that may be connected to a variety of devices, such as remote displays, controllers, and recorders.

In most respects dial-reading and Digital Viscometers are functionally similar. The operating procedures for both are essentially the same, they are available in the same model variations, they accept the same Brookfield accessories, and are generally

interchangeable (model for model) in most viscosity specifications requiring Brookfield Viscometers.

The dial-reading type is the least expensive Brookfield Viscometer and is suitable for most applications where samples are to be tested over a short period of time and a permanent detailed record of rheological behavior is not required. This is due to the fact that while the Viscometer rotates continuously, readings may be made only intermittently, when the pointer passes under the vision glass, or when the reading is held and the Viscometer stopped. Long term viscosity tests necessitate frequent operator attention, and some fast-acting processes dictate continuous monitoring.

The Digital Viscometer, with its continuous sensing and display, is more suited to such situations. It may be left unattended for long periods, and the data output (DV-II+ Pro) may be adjusted to provide a detailed record of even the fastest rheological processes. In addition, many operators prefer a digital display, which eliminates the interpolation sometimes necessary when reading a dial. Both types offer equivalent accuracy.

Brookfield Digital Viscometers (excluding DV-E) are also available in cone/plate geometry. See Section 2.10 for more information on cone/plate spindle geometry.

Several specialized viscometers are available which have been designed to satisfy particular industry needs. These instruments are unique and do not necessarily compare to the traditional Brookfield Viscometer. The Brookfield KU-2 is designed to provide a viscosity measurement in Krebs units and is often used in the paint industry. The Brookfield CAP-1000+ is designed to operate at high shear rate ( $10,000 \text{ s}^{-1}$ ,  $12,000 \text{ s}^{-1}$ ) and is often used in the resin and paint industries.

### 2.3 Rheometers

A very important advancement in viscosity measurement is the bidirectional DV-III Ultra Rheometer (and more recently, the DV-II+ Pro Viscometer) for use with PC. This instrument, with variable speed capability, allows easy handling and programming of complicated

application measurements. It also enables the storage of calculated results and transfer of data to Excel or any LIMS system. When used with Brookfield Rheocalc software, it easily gives a graphical view of results which is especially important on flow curve interpretations. The overlay capability of the Rheocalc software gives a good possibility to compare different measured results from multiple tests.

The Brookfield R/S+ Rheometer differs from the standard Brookfield viscometers in that it is a controlled stress (or controlled torque) instrument rather than a controlled rate (RPM) instrument. Controlled stress with the R/S provides many benefits such as a very broad viscosity measurement range, testing for Yield properties and the ability to measure flow properties of delicate high viscosity gels. Similar to DV-III Ultra, it can operate in stand alone mode or under PC control and provides detailed data on material behavior, including yield stress.

The CAP 2000+ Rheometer is a variable speed cone/plate instrument with broad shear rate capability. Its rugged design makes it ideal for busy work environments whether running in stand alone mode or under PC control.

The PVS Rheometer is a “pressurizable variable speed” instrument used primarily to evaluate fracturing fluids and drilling muds in the oil/gas industry.

The relatively new YR-1 Rheometer is an inexpensive benchtop instrument which tests the yield behavior of materials, providing a single yield stress value for better QC evaluation of products.

## **2.4 Spindle Geometries**

All Brookfield Viscometers and Rheometers are supplied with spindles suitable for most applications within the viscosity range of the instrument. There are, however, situations where specialized spindle geometries are necessary to obtain optimum results. Brookfield has available a wide variety of spindles and accessories to fulfill these needs.

All Brookfield spindles are constructed of 300 series stainless steel for maintenance-free service in most applications; some are available coated for maximum corrosion resistance. Brookfield also offers disposable spindle and chambers made of aluminum as noted in this section. Please inquire about special spindle materials and configurations for unusual applications.

### **2.4.1 Disc Spindles**

Provided as standard equipment with LV (spindles #2 and #3) and RV/HA/HB models (spindles #2 through #6), these are general-purpose spindles for use in containers of 600 mL capacity or larger. Disc spindles produce accurate, reproducible apparent viscosity determinations in most fluids. The results obtained can be converted into viscosity functions by a mathematical procedure outlined in Technical Paper AR-82, available from Brookfield Engineering Laboratories. See Section

2.9 for information on spindle geometries that directly provide defined shear rates.

### **2.4.2 Cylindrical Spindles**

These spindles (LV #1 and #4, RV/HA/HB #7) provide a defined spindle geometry for calculating shear stress and shear rate values as well as viscosity, when used with the Brookfield Guard Leg. In all other respects their operating parameters are similar to those of disc spindles.

Because their defined geometry facilitates mathematical analysis, cylindrical spindles are particularly valuable when measuring non-Newtonian fluids. They are applicable to any Brookfield Viscometer model with the use of the appropriate range sheet. Cylindrical equivalents of the LV #2 and #3 disc spindles are also available. See Section 2.9 for information on other defined shear rate geometries.

### **2.4.3 Coaxial Cylinders**

Coaxial-cylinder geometry is indicated for applications where extremely well-defined shear rate and shear stress data is required, particularly when the sample volume is relatively small. Several Brookfield accessories feature coaxial-cylinder geometry; each also has unique advantages for specific situations. These accessories are: the Small Sample Adapter (Section 2.6.1), the UL Adapter (Section 2.6.2), the Thermosel (Section 2.6.4), the DIN Adapter (Section 2.6.3) and the Spiral Adapter (Section 2.12.2).

Disposable chambers and spindle are available for Small Sample Adapter and Thermosel. Please read 2.6.1 and 2.6.4 for details.

### **2.4.4 Cone/Plate Geometry**

Cone/plate geometry offers absolute viscosity determinations with precise shear rate and shear stress information readily available. The sample volumes required are extremely small and temperature control is easily accomplished. Cone/plate geometry is particularly suitable for advanced rheological analysis of non-Newtonian fluids. It is available on the Wells-Brookfield Cone/Plate Viscometers, CAP 2000+ Rheometer and R/S+ Rheometer (see Section 2.10 for more information).

### **2.4.5 T-Bar Spindles**

Generally used in conjunction with the Helipath Stand accessory (with which they are supplied as standard equipment), T-bar spindles make possible the measurement of non-flowing or slow-flowing materials such as pastes, gels, and creams. Results are considered “apparent” since the unique geometry of the T-bar spindle prevents the calculation of shear rate or shear stress. See Section 2.12.1.

### 2.4.6 Vane Spindles

The vane spindle, when immersed into a material, traps a portion of the test sample creating a "cylinder" of sample that can be used to calculate shear stress and shear rate. With vane spindles, well-defined measurements are possible for non-flowing or slow-flowing fluids, including yield values. Four vane spindles are available and can be used with most Brookfield viscometers. See Section 2.12.3.

## 2.5 Temperature Control

In order to ensure maximum accuracy and reproducibility in many viscosity measurement procedures, temperature control is highly recommended. The following systems are available from Brookfield:

### 2.5.1 Temperature Baths

Constant-temperature baths are suitable for most viscosity measurement applications. They are available in two basic types: circulating, for use with jacketed devices such as the Wells-Brookfield Cone/Plate Viscometer (Section 2.10.1) and the Small Sample Adapter (Section 2.7.2); and reservoir/circulating, for all applications (this type can be used with jacketed devices as well as with any sample container that can be immersed in the bath's reservoir). Temperature baths are generally limited to a maximum operating temperature of approximately 120°C (depending on the bath fluid used), and usually require auxiliary cooling devices for operation at or below ambient temperature. Refrigerated baths are also available. Contact Brookfield Engineering Laboratories or your dealer for more information.

### 2.5.2 Thermosel System

This system is designed for the measurement of small samples in the temperature range of approximately 40° to 300°C. Unlike a temperature bath, the Thermosel doesn't utilize a fluid medium for temperature control. For more information, see Section 2.8.

### 2.5.3 Peltier (Thermo-electric Systems)

The Cap 1000 Viscometer, CAP 2000 Rheometer and the R/S CPS-P1 Rheometer have an embedded peltier device in the sample plate to provide rapid temperature control. Small sample size (less than 1 mL) facilitates easy temperature profiling of materials.

## 2.6 Small Sample Volume

The standard sample container for most Brookfield Viscometers is a 600 ml low form Griffin beaker. Users often find it desirable or necessary to measure samples of smaller volume. Several Brookfield products feature small sample volumes.

## 2.6.1 Small Sample Adapter

Specifically designed to facilitate the measurement of small samples, the Small Sample Adapter (SSA) is a jacketed, coaxial-cylinder accessory that is compatible with all Brookfield Viscometers with the exception of cone/plate types. Depending on the model selected, the Small Sample Adapter utilizes sample volumes of 2.0 to 16.0 ml. Also depending on model, the Small Sample Adapter will measure viscosities from 5 cP to 10,000,000 cP at shear rates from 0.066 to 93.0 reciprocal seconds. The Small Sample Adapter's jacketed design permits connection to a circulating-type bath for excellent temperature control up to a recommended maximum of 100°C. Disposable 13RD chamber is available for use with SSA; a special water jacket is required for this configuration.

### 2.6.2 UL Adapter

The UL Adapter is primarily intended to allow viscosity measurements in ranges below those normally measurable by a particular Viscometer. When used with its removable end cap in place, the UL Adapter measures a sample volume of 16.0 mL. For more information, see Section 2.7.1

### 2.6.3 DIN Adapter

DIN standards come from Germany and are similar in scope and purpose to ASTM standards from the United States.

The Brookfield DIN Adapter, like the UL Adapter, is designed to measure in ranges below those normally measured with a particular Viscometer. The DIN Adapter utilizes additional DIN spindles for measurement ranges from 1 cP to 50,000 cP and conforms to DIN 53019.

### 2.6.4 Thermosel System

The Thermosel System allows the measurement of viscosity at temperatures to 300°C. It incorporates coaxial-cylinder spindle geometry that uses a sample volume of 8.0 to 13.0 ml, depending on the spindle utilized. See Section 2.8.1

Disposable chambers (Part No. HT-2D-100) and spindle (Part No. SC4-27D) are available for use with Thermosel.

### 2.6.5 Cone/Plate Systems

When sample volume is extremely limited, it may be necessary to use cone/plate geometry. The Wells-Brookfield Cone/Plate geometry requires a sample of only 0.5 to 2.0 mL, depending on spindle. More data on this instrument will be found in Section 2.10.1

The CAP and R/S Cone/Plate geometries require <1mL for sample volume. See Section 2.10 for details.

## 2.7 Low Viscosity

Each Brookfield Viscometer and Rheometer measures a wide range of viscosities; however, it occasionally becomes necessary to measure viscosities below the normal range of the instrument. Several pieces of Brookfield equipment offer this capability:

### 2.7.1 UL Adapter

This accessory was specifically designed to provide greater sensitivity at low viscosities for the LV series Viscometers; it can, however, be used on any model Brookfield Viscometer. When mounted on an LVT Viscometer, the UL Adapter provides a viscosity range of 1.0 to 10.0 cP and a defined shear rate of 73.4 reciprocal seconds at 60 RPM. For other Viscometer models, the minimum measurable viscosity with the UL Adapter in place is: RVT, 6.4 cP; HAT, 12.8 cP; HBT, 51.2 cP. The UL Adapter features coaxial-cylinder geometry with a removable polyethylene end cap for the outer cylinder. With the end cap in place, the Adapter holds a sample volume of 16.0 ml and can be immersed in a bath for temperature control up to a recommended maximum of 100°C; with the cap removed it may be used in sample containers of almost any size.

### 2.7.2 Small Sample Adapter

With some spindle/chamber combinations, the Small Sample Adapter permits measurement of viscosities below the Viscometer's normal range. Check the applicable range sheet for details. More information on the Small Sample Adapter can be found in Section 2.6.1

### 2.7.3 Thermosel System

With certain spindles, the Thermosel System provides increased sensitivity at low viscosities; check the applicable range sheet for more data. The Thermosel System is discussed in more detail in Section 2.8.1

### 2.7.4 Wells-Brookfield Cone/Plate Viscometer

The Wells-Brookfield Cone/Plate Viscometer has measurement capabilities below 1.0 cP. See Section 2.10 for more information on this instrument.

## 2.8 High Temperature

Measurement of viscosity at high temperature can be simple or complex, depending upon the sample materials and temperature. Sometimes all that is necessary is to increase the distance between the Viscometer and sample material through use of spindle extensions (see Section 2.13). In difficult applications, such as the measurement of molten glass, it may be necessary to utilize a specialized furnace and crucible, as well as custom-designed spindles constructed of heat resistance materials (consult with Brookfield Engineering Laboratories for more information on this type application). Between these two extremes, there is

Brookfield equipment for most high temperature viscosity measurement applications.

### 2.8.1 Thermosel System

The Thermosel System is specifically designed for viscosity measurement of small samples in the temperature range of approximately 40 to 300°C. It is usually sold as a complete system including Viscometer, but is also available as an accessory to your present Viscometer (except cone/plates).

In addition to the Viscometer, the Thermosel System consists of a special coaxial-cylinder spindle and sample chamber, an electric heating apparatus called a thermocontainer, and a digital proportional temperature controller with RTD sensor. The Thermosel System is available in three variations: System 1 is a manual unit with a dial-reading Viscometer; System 2 includes a Digital Viscometer and outputs for recording viscosity and temperature; and System 3, which adds the capabilities of a fully programmable temperature controller to the features of System 2 with or without a PC control.

The Thermosel System requires small sample volumes (8.0 to 13.0 ml, depending on spindle), and its coaxial-cylinder spindle geometry provides defined shear rates in the range of 0.08 to 93.0 reciprocal seconds, depending on spindle and Viscometer model.

### 2.8.2 Temperature Baths

Brookfield Temperature Baths are also suitable for viscosity measurements at high temperature. Certain models have a maximum operating temperature of 200°C. For more information, see Section 2.5.

### 2.8.3 Cone/Plate with Embedded Heating

CAP series Viscometer/Rheometer with high temperature plate can heat samples to 325°C, which is ideal for certain resins. The R/S Rheometer has similar capability in a special cone/plate version (R/S-CPS-E) which goes to 250°C. Since sample size is relatively small, temperature equilibrium is achieved rapidly.

## 2.9 Defined Shear Rate

For applications where viscosity data must be expressed in absolute terms, it is necessary to use a spindle geometry for which shear rate and shear stress values can be calculated. Such defined operating parameters are found in the following Brookfield instruments and accessories. Consult the referenced sections for more information about these products:

Cylindrical Spindles	2.4.2
Small Sample Adapter	2.6.1
UL Adapter	2.6.2
DIN Adapter	2.6.3
Thermosel System	2.8.1
Wells-Brookfield Cone/Plate Viscometer	2.10.1

CAP Viscometer	2.10.2
R/S Rheometer	2.10.3
PVS Rheometer	2.10.4

## 2.10 High Shear Rate

Brookfield Viscometers are, by design, relatively low-shear instruments. The maximum shear rate achievable with most spindle configurations is usually less than 100 reciprocal seconds. Defined shear rates in the range of up to 300 reciprocal seconds can be generated by some Viscometer models when used in conjunction with the UL Adapter (Section 2.1.6), the Small Sample Adapter (Section 2.1.5), or as part of the Thermosel System (Section 2.1.7). For shear rates in excess of 300 reciprocal seconds it is usually necessary to use the Wells-Brookfield Cone/Plate, CAP, PVS Rheometer or R/S Rheometer.

### 2.10.1 Wells-Brookfield Cone/Plate Viscometer/Rheometer

The Wells-Brookfield Cone/Plate Viscometer will determine the absolute viscosity of small samples under conditions of defined shear rate and shear stress. Its cone and plate spindle geometry requires a sample volume of only 0.5 to 2.0 mL and generates shear rates in the range of 0.6 to 1,875 reciprocal seconds (depending on model and spindle used). The instrument's sample cup is jacketed for excellent temperature control.

Depending on the particular model and spindle in use, the Wells-Brookfield Cone/Plate will measure viscosities from 0.1 cP to 2.6 million cP (although no single instrument will cover this range, the use of several spindles will allow one instrument to measure a wide range of viscosities).

The Wells-Brookfield Cone/Plate Viscometer is available in different Digital versions. A temperature bath is optional and highly recommended for precise and reproducible viscosity measurements.

The cone and plate spindle geometry is available only on the Wells-Brookfield Cone/Plate instrument; it is not available as an accessory or modification of other Brookfield Viscometers. It is possible to use this instrument with standard disc and cylindrical spindles; however, an extension for the laboratory stand is required to provide sufficient clearance under the Viscometer.

### 2.10.2 CAP Viscometer/Rheometer

The Brookfield CAP series of Cone/Plate Viscometers offer high shear rates and variable speeds in an instrument optimized for R&D and QC applications such as paints, coatings, resins, inks, cosmetics, pharmaceuticals and foods. These series of viscometers have integrated temperature control for test sample volume of less than 1 mL.

The CAP 1000+ is a single speed viscometer running at 750 RPM on 50 Hz and 900 RPM on 60 Hz, generating shear rates at 10,000 or 2,500 sec<sup>-1</sup> at 50 Hz and 12,000 or 3,000 sec<sup>-1</sup> at 60 Hz de-

pending on choice of spindle. The CAP 2000+ is a variable-speed instrument and has variable shear rate capability over the speed range from 5 to 1,000 RPM. This instrument generates shear rates from 166 to 13,300 sec<sup>-1</sup> at viscosity ranges from 0.1 to 1,500 Poise (0.1 to 150 Pa•s). The CAP Series+ meets industry test standards BS3900, ISO 2884, and ASTM D-4287.

The CAP Viscometer offers choice of low torque or high torque capability; selection is based on viscosity range of samples to be tested.

### 2.10.3 R/S+ Rheometer

R/S+ Rheometer can generate shear rates up to 5,100 sec<sup>-1</sup> in narrow gap coaxial cylinder geometry and up to 6,000 sec<sup>-1</sup> in cone/plate. Maximum instrument speed is 1000 RPM.

### 2.10.4 PVS Rheometer

The Brookfield PVS Rheometer is a portable unit designed for measuring viscosity at high pressure and temperature. Its ability to measure viscosity over a pressure range from ambient up to 1,000 psi and a temperature range of -40°C to 200°C makes it ideal for applications such as oil and gas well drilling fluids, pulp and paper, plastics, petrochemicals, and aerosol based products.

The PVS Rheometer operates at shear rates from 0.01 sec<sup>-1</sup> to 1,700 sec<sup>-1</sup> corresponding to speed ranges from 0.05 to 1,000 RPM. The PVS Rheometer torque sensor is unaffected by changes in pressure or temperature; the placement of bearings outside the pressurized sample volume virtually eliminates the need for maintenance.

## 2.11 Defined Shear Stress

### R/S Series Rheometer

The Brookfield R/S Rheometer differs from the standard Brookfield viscometers in that it is a controlled stress (or controlled torque) instrument rather than a controlled rate (RPM) instrument. Controlled stress with the R/S provides many benefits such as a very broad viscosity measurement range, testing for Yield properties and the ability to measure flow properties of delicate high viscosity gels.

The R/S Rheometer is available in several models. The coaxial Cylinder Model offers DIN geometries with bob/spindle diameters of 8, 14, 25, 45, 48 mm and double gap. The Cone/Plate Model offers 1 and 2 degree cones of 2.5, 5.0 and 7.5 cm diameter. The Cone/Plate Model also functions as a Plate/Plate Model by using flat plates ranging from 2.5, 5.0 and 7.5 cm diameter. The flat plate geometries are a good choice for extremely high viscosity fluids, or where the fluid has solid particles in it.

### R/S Soft Solids Tester

The R/S Soft Solids Tester combines vane spindle geometry with low shear and stress, providing viscoelastic characterization of soft solid mate-

rials such as pastes, gels, waxes and slurries. Brookfield Rheo 2000 software with soft solids module is required.

## **2.12 Non-Flowing Sample Materials**

Non-flowing or slow-flowing sample materials such as pastes, creams, and gels present special problems in viscosity measurement. Conventional rotating spindles tend to “channel” (push the sample material aside), resulting in a continuously decreasing Viscometer reading that is of little value. Several alternatives address this problem.

### **2.12.1 Helipath Stand**

The Helipath Stand is a motorized stand to which any Brookfield Viscometer can be attached. The Stand slowly raises and lowers the Viscometer (at a rate of 7/8-inch per minute) while a special T-bar spindle rotates in the sample material. The cross-bar of the spindle thus continuously cuts into fresh material, describing a helical path through the sample as it rotates. The “channeling” effect of conventional spindles is completely eliminated permitting meaningful viscosity/consistency measurements to be made. A set of six T-bar spindles and a special coupling are included with the Helipath Stand.

### **2.12.2 Spiral Adapter**

The Brookfield Spiral Adapter accessory is a pump-type sensor that directly measures viscosity of pastes, including applications such as solder paste, foods, cosmetics and pharmaceuticals. The Spiral Adapter has an inner, threaded spindle surrounded by a concentric outer cylinder. This combination causes the sample to be continually pumped up through the Spiral Adapter. The material reaches a steady state of flow during which viscosity is measured. The steady-state measurement is less sensitive to sample handling and minor material variations than other viscosity measuring methods.

### **2.12.3 Vane Spindles**

Vane Spindles immerse directly into the sample material without causing disturbance. The material trapped between the vanes will move as the spindle rotates. The net effect is that a virtual cylinder of sample material, in which the vane spindle is inscribed, will flow at defined rotational speeds, thereby providing complete flow curve data for viscosity analysis. Vane spindles can be used with standard Brookfield Viscometers/Rheometers and R/S-SST Rheometer.

## **2.13 Special Accessory Items**

The following items can be purchased for use with Brookfield Viscometers/Rheometers.

### **2.13.1 Quick Connect**

The Brookfield Quick Connect accessory is designed to quickly attach or remove a spindle from a Brookfield Viscometer/Rheometer resulting in time savings and elimination of cross threading. The Quick Connect accessory is made of stainless steel and can be used with LV, RV/HA/HB disk spindles, cylindrical spindles, as well as T-bar couplings.

### **2.13.2 Spindle Extensions**

Spindle extensions are suitable for applications utilizing standard disc or cylindrical spindles where distance between the Viscometer and the sample material must be increased (up to 6 feet maximum). Type D extensions are installed between the Viscometer and the spindle, and are suitable for applications where depth of the spindle immersion can be observed. Type S extensions include the immersed portion of the spindle and are used where depth of immersion is not observable.

## **2.14 Fumes and Hazardous Locations**

Whenever fumes and vapors are present that could enter the Viscometer, care should be taken to prevent such entry. When the fumes are explosive or flammable, special precautions are required not only for protection of the Viscometer, but for the safety of nearby personnel.

### **2.14.1 Purge Fittings**

A purge fitting may be provided on the pivot housing of any Viscometer. An inert gas such as nitrogen is introduced under low pressure through the purge fitting, creating a positive pressure inside the Viscometer housing which prevents entry of fumes and vapors.

Purge fittings are also available for sample cups of the Wells-Brookfield Cone/Plate Viscometer to provide a controlled atmosphere for the sample being tested.

### **2.14.2 Explosion-Proof Construction (Dial Viscometer Only)**

When the danger of explosion is great due to the presence of flammable fumes or other factors, use of approved explosion-proof equipment may be required. Brookfield dial-reading Viscometers (except cone/plate types) are available in Underwriters' Laboratory (UL) approved explosion-proof versions. These instruments are approved for Class I, Group D hazardous locations. The Digital Viscometers and Rheometers are not available with explosion-proof construction.

Electrically operated Brookfield accessories, such as the Helipath Stand and the Thermosel, are not available in explosion-proof versions. They can be used with explosion-proof Viscometers (sometimes requiring special adapters), but only in non-hazardous environments.

## 2.15 Process Control

Practical application of viscosity data obtained in the laboratory often involves use of on-line process viscometers and viscosity controllers. Brookfield manu-

factures a complete line of instrumentation that has been applied to a wide variety of process control applications. Please contact Brookfield Engineering Labs for more information.

# CHAPTER 3

## 3.1 Why You Should Read This Chapter

The purpose of this chapter is to provide the Viscometer user with information necessary to make meaningful viscosity measurements. It will describe the mechanical components of the Brookfield Viscometer and suggest some useful operational techniques.

Those adhering strictly to the Pragmatic school of viscosity measurement may not wish to read any further than this chapter. All users, however, should read it before moving on; a good grounding in basic Viscometer operation will facilitate advancement to more sophisticated techniques.

## 3.2 How the Brookfield Viscometer Works

The Brookfield Viscometer is of the rotational variety. It measures the torque required to rotate an immersed element (the spindle) in a fluid. The spindle is driven by a motor through a calibrated spring; deflection of the spring is indicated by a pointer and dial (or a digital display). By utilizing a multiple speed transmission and interchangeable spindles, a variety of viscosity ranges can be measured, thus enhancing versatility of the instrument.

For a given viscosity, the viscous drag, or resistance to flow (indicated by the degree to which the spring winds up), is proportional to the spindle's speed of rotation and is related to the spindle's size and shape (geometry). The drag will increase as the spindle size and/or rotational speed increase. It follows that for a given spindle geometry and speed, an increase in viscosity will be indicated by an increase in deflection of the spring. For any Viscometer model, the minimum range is obtained by using the largest spindle at the highest speed; the maximum range by using the smallest spindle at the slowest speed. Measurements made using the same spindle at different speeds are used to detect and evaluate rheological properties of the test fluid. These properties and techniques are discussed in Chapters 4 and 5.

The Viscometer is composed of several mechanical subassemblies. See Figure 3-1 for a schematic view of the major components of a basic dial-reading Viscometer.

The stepper drive motor (which replaced the synchronous motor and multiple-speed transmission) is located at the top of the instrument inside the housing to which the nameplate is attached. The Viscometer main case contains a calibrated beryllium-copper spring, one end of which is attached to the pivot shaft, the other end is connected directly to the dial. This dial is driven by the motor drive shaft and in turn drives the pivot shaft through the calibrated spring. In dial-reading models, the pointer is connected to the pivot shaft and indicates its angular position in relation to the dial. In Digital models, the relative angular position of the pivot shaft is detected by an RVDT (rotary variable displacement transducer) and is read out on a digital display.

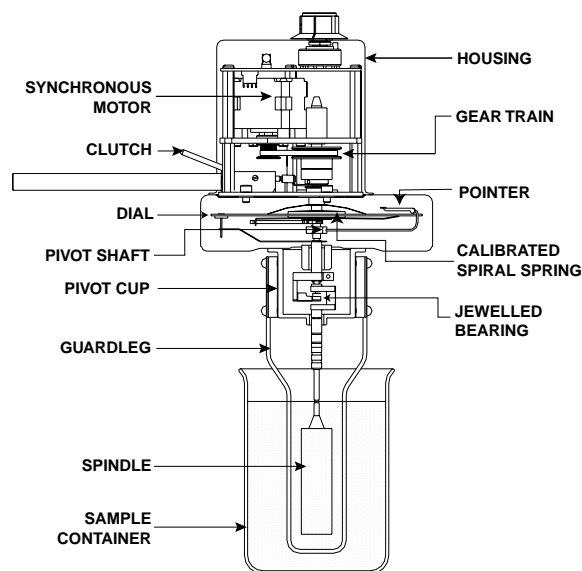

Figure 3-1

Below the main case is the pivot cup through which the lower end of the pivot shaft protrudes. A jewel bearing inside the pivot cup rotates with the dial or transducer; the pivot shaft is supported on this bearing by the pivot point. The lower end of the pivot shaft comprises the spindle coupling to which the Viscometer's spindles are attached.

### 3.3 Spring Torque

There are four basic spring torque series offered by Brookfield:

<b>Brookfield Terminology</b>	<b>Spring Torque</b>	
	<u>dyne-cm</u>	<u>milli Newton - m</u>
LV	673.7	0.0673
RV	7,187.0	0.7187
HA	14,374.0	1.4374
HB	57,496.0	5.7496

The higher the torque calibration of your instrument, the higher the viscosity measurement range for a specific spindle. The viscosity measurement range for each torque calibration and spindle combination may be found in Appendix B.

There are many variations of the standard spring torques. Please consult Brookfield Engineering Laboratories or your dealer with your special requirements.

### 3.4 Viscosity Measurement Techniques

As with any precision instrument, proper operating techniques will improve effectiveness of the Brookfield Viscometer. A step-by-step procedure for Viscometer operation can be found in the Instruction Manual supplied with each unit, and is not repeated here. Instead, we present recommendations and advice gleaned from over 70 years of customer experience. They form a sound foundation for a viscosity testing procedure and a starting point from which more advanced techniques can be explored.

#### 3.4.1 Record Keeping

We recommend that the following information always be recorded when making a viscosity measurement; viscometer model, spindle (or accessory), rotational speed, container size or dimensions, sample temperature, time of spindle rotation, sample preparation procedure (if any), and whether or not the spindle guardleg was used. Test Report Forms supplied in the instruction manual with each Viscometer are convenient for this purpose.

#### 3.4.2 The Spindle and the Guardleg

Examine each spindle before using it. If it is corroded or damaged to the extent of changing its dimensions, a false viscosity reading may result. Since all spindles are brightly polished when new, any sign of pitting, dulled edges, or other obvious damage should dictate the purchase of a new spindle. If you have an unusual problem along these lines, corrosion-resistant 316 series stainless steel and Teflon-coated spindles are available. Also, special spindle materials can be employed.

When attaching a spindle, remember that it has a **left-hand** thread and must be screwed firmly to the coupling. Always lift up on the spindle coupling when attaching a spindle to avoid damage to the instrument's pivot point and jewel bearing. After at-

tachment, do not hit the spindle against the side of the sample container since this can damage the shaft alignment. A good procedure to follow is to immerse and position the spindle in the sample fluid before attaching it to the Viscometer.

The spindle guardleg (supplied with some models) protects the spindle from damage and is significant to the Viscometer's calibration when using the #1 or #2 spindle. The guardleg should be used at all times. If it proves necessary or desirable to operate the Viscometer without the guardleg, this fact should be noted when reporting test results. It may be desirable to recalibrate the Viscometer to compensate for the absence of the guardleg. Refer to Section 3.3.10 for this procedure.

Note: spindle guardlegs are provided only on LV and RV models of the dial-reading and Digital Viscometers with standard spindles. HA and HB models, as well as Cone/Plate models, do not require a guardleg. The guardleg is also not used in conjunction with most accessories.

#### 3.4.3 Selecting a Spindle Speed

When performing a test according to an existing specification or procedure, use the spindle and speed specified (after confirming that you have the correct Viscometer model). When conducting an original test, the best method for spindle and speed selection is trial and error. The goal is to obtain a Viscometer dial or display (% torque) reading between 10 and 100, remembering that relative error of measurement improves as the reading approaches 100 (see Section 3.3.7). If the reading is over 100, select a slower speed and/or a smaller spindle. Conversely, if the reading is under 10, select a higher speed and/or a larger spindle.

If the approximate viscosity of the sample fluid is known, a faster method for honing in on the right spindle/speed combination is available by referring to the Factor Finder supplied with the Viscometer. The goal is to select a combination whose range brackets the estimated viscosity of the sample.

For any given spindle/speed combination, the **maximum** range available is equal to the spindle Factor multiplied by 100. This maximum is also called "Full Scale Range" or "FSR". For Digital Viscometers that have the AUTORANGE key, selecting a speed and spindle and then depressing and holding the AUTORANGE key will cause the screen to display FSR in cP (mPa•s).

The **minimum** recommended range equals the Factor multiplied by 10. For example: a #2 spindle on an LVT Viscometer at 12 RPM has a Factor of 25. The maximum range of this combination is 25 times 100, or 2500 cP. The minimum recommended viscosity that should be measured is 25 times 10, or 250 cP. Therefore, if the viscosity of the sample fluid is estimated to be 4000 cP, another spindle/speed combination must be selected in order to

make the measurement. If the sample fluid is around 2000 cP, however, this spindle and speed would be suitable. With a little practice, a quick glance at the Factor Finder will suffice to make an appropriate selection of spindle and speed.

When conducting multiple tests, the same spindle/speed combination should be used for all tests. When a test must be performed at several speeds, select a spindle that produces on-scale readings at all required speeds. This may necessitate using a dial or display reading less than 10, which is acceptable as long as the reduced accuracy of such a reading is recognized.

### 3.4.4 Sample Container Size

For measurements with standard Viscometer models we recommend a container with an inside diameter of 3 1/4 inches (83 mm) or larger. The usual vessel for this purpose is a 600 mL low form Griffin beaker. Use of a smaller container will result in an increase in viscosity readings, particularly with the #1 and #2 spindle.

When utilizing a smaller container, the simplest approach is to report the dimensions of the container and ignore the probable effect on calibration. As long as the same size container is used for all subsequent tests, there will be no correlation problem.

Alternatively, the Viscometer can be recalibrated to compensate for the smaller container as outlined in Section 3.3.10. Also, use of the Small Sample Adapter should be considered. See Section 2.6.1.

### 3.4.5 Sample Conditions

The sample fluid should be free from entrapped air. Air can be removed by gently tapping the container on a table top or by careful use of a vacuum apparatus.

The sample should be at a constant and uniform temperature. This can be verified by checking the temperature at several different locations within the container. Be sure to bring the sample, spindle, and guardleg to the same temperature before taking a viscosity reading. Temperature uniformity can often be maintained by agitation prior to a measurement, but first determine that such agitation won't affect viscosity of the sample fluid (see Section 4.7.5). Factors used to calculate viscosity values from the Viscometer readings are independent of temperature.

A constant temperature water bath is used to maintain the desired temperature. Refer to Section 2.5 for information on recommended baths.

High temperature work (up to 300°C) may require use of the Thermosel accessory. See Section 2.8.1.

Homogeneity of the sample is also quite important, especially in dispersed systems where settling can occur. In many cases, simple stirring just prior

to the test will keep the components dispersed.

### 3.4.6 Spindle Immersion

The spindle should be immersed up to the middle of the shaft indentation. Failure to do so could result in incorrect viscosity readings.

In some cases the sample fluid may change its rheological structure during the act of spindle immersion. To avoid this, we recommend inserting the spindle in a different portion of the sample than the one intended for measurement. The spindle may then be moved horizontally to the center of the sample container. This must be done before attaching the spindle to the Viscometer.

### 3.4.7 Sensitivity and Accuracy

Brookfield Viscometers are guaranteed to be accurate to within  $\pm 1\%$  of the full-scale range of the spindle/speed combination in use (this percentage, expressed in centipoise values, is equal to the spindle Factor; accuracy of a spindle/speed combination with a factor of 25 would therefore be within  $\pm 25$  cP). Repeatability is to within  $\pm 0.2\%$  of the full scale range.

The relative error of a particular viscosity reading is dependent upon the actual dial or display (% torque) reading. In general, relative error of the viscosity value will improve as the reading approaches 100. This is because the tolerance of  $\pm 1\%$  of full-scale viscosity applies to all readings, and represents a smaller percentage of measured viscosity as the actual reading increases. Consider the following example:

An LVT Viscometer, when used with a #1 spindle at a speed of 60 RPM, has a spindle Factor of 1 (obtained from the Factor Finder supplied with each instrument). Since the full-scale range of any spindle/speed combination is equal to the Factor multiplied by 100, the full-scale viscosity range in this case is 100 cP. The accuracy tolerance is  $\pm 1\%$  of this range, or 1 cP, irrespective of the Viscometer's dial or display reading. Refer to the following table to see how this affects the accuracy of various readings taken with this spindle/speed combination:

Viscometer Reading	Viscosity	Possible Error	Relative Error
100	100 cP	1 cP	1%
50	50 cP	1 cP	2%
10	10 cP	1 cP	10%

The same principle applies to the repeatability of the reading. As with accuracy, the potential error introduced by the repeatability tolerance becomes less significant as the dial or display reading increases.

### 3.4.8 Obtaining a Viscometer Reading

Before operating the Viscometer, be sure that it

is securely attached to its stand and has been properly leveled. Select a spindle and speed combination and attach the spindle to the Viscometer. Don't mix LV and RV spindles.

Turn the Viscometer on and allow it to run until a constant reading is obtained. Be prepared, however, for some overshoot since momentum gained by the spindle during acceleration may cause the reading to initially oscillate about the final equilibrium value.

A number of procedures can be employed to obtain a satisfactory reading. In some cases, as much as 5 minutes must be allowed for the reading to reach apparent equilibrium. Usually you can just wait until the reading appears relatively constant for a reasonable time.

A more repeatable procedure is to specify a definite number of spindle revolutions to be counted before taking a reading. Since the time required for a certain number of revolutions will differ significantly with the speed in use, an alternate method is to let the spindle rotate for a specified period of time.

You may find that the reading does not come to equilibrium but continues to oscillate. This is usually due to the presence of an elastic as well as a viscous component in the fluid. If the reading continually increases or decreases, the fluid is probably time-dependent and requires special techniques to be measured successfully. See Section 4.5.

The torque display on the Digital Viscometer may fluctuate by 0.1 or 0.2% even after equilibrium is reached. If this happens, simply use the median value as the accepted reading. Larger fluctuations may indicate the conditions described in the preceding paragraph.

Once a valid reading is obtained with a Dial Reading Viscometer, multiply it by the Factor for the spindle/speed combination you are using. The Factor will be found on the Factor Finder supplied with the Viscometer. Calculating Digital Viscometers do not require the use of a factor. These viscometers will display viscosity (in units of cP) directly, provided the spindle number has been entered (refer to the instruction manual of your viscometer).

A note about Factors and Ranges; both can be used to calculate viscosity from a given reading. A Factor (such as that obtained from the Factor Finder) is simply multiplied by the Viscometer reading to calculate viscosity (in centipoise). A Range (as supplied with some Brookfield Accessories in lieu of a Factor) is equal to the Factor multiplied by 100. Therefore, to calculate viscosity, first divide the Range by 100, then multiply by the Viscometer dial or display reading.

#### 3.4.9 A Calibration Check

People are often concerned about the accuracy of their Viscometer. Here are some tests of its me-

chanical performance:

(A) Variations in power frequency will cause the spindle to rotate at an incorrect speed. If you are in an area where electric clocks are used, this factor may be immediately eliminated. Voltage variations have no effect as long as the deviation is not greater than  $\pm 10\%$  of the nameplate voltage and the frequency remains constant.

Other readily apparent symptoms of improper power supply are: failure of the motor to start, jerky spindle rotation, a wildly fluctuating pointer, or inconsistent digital display readings.

(B) Damage to the pivot point or jewel bearing will adversely affect accuracy and repeatability of the Viscometer. The following Oscillation Test will allow you to evaluate the condition of these components:

1. The Viscometer should be mounted and leveled, with no spindle installed and the power switch in the "off" position for Dial Reading Viscometers; Digital Viscometers should have the power on, autozero performed and the motor off.
2. Turn the spindle coupling to deflect the pointer or digital display upscale from its zero position to a torque reading of 5 to 10 and let it swing back under its own power.
3. If the pointer swings freely and smoothly, and returns to within  $\pm 0.2\%$  of zero each time this test is repeated, the pivot point and jewel bearing are in good condition. If it crawls back or sticks on the dial, performance of the Viscometer will not be up to specification, and it should be serviced. On Digital Viscometers the digital display should fluctuate smoothly and return to within  $\pm 0.2\%$  of zero reading.

(C) We have never found a spring made of beryllium copper which showed any change in its characteristics due to fatigue, even after hundreds of thousands of flexings. For this reason, a check of the calibrated spring is usually not necessary.

(D) Use of a calibrated viscosity standard is recommended as a final performance check. Test the viscosity standard as you would any sample fluid, carefully following any applicable instructions. Brookfield Viscosity Standards (calibrated to within  $\pm 1\%$ ) are ideal for this test. The use of fluids other than viscosity standards is not recommended due to the probability of unpredictable rheological behavior.

(E) If the Viscometer passes all of the preceding tests, its performance should be satisfactory. Should accuracy or operation of the instrument still be suspect, please refer to the troubleshooting chart in Section 3.5.

#### 3.4.10 Recalibrating the Brookfield Viscometer

In many cases it is not practical to use a 600 mL low form Griffin beaker when making measurements

with a Brookfield Viscometer. It may be desirable to use a different container if transferring the material proves messy or time-consuming. Sometimes people also use the instrument without the guard leg to avoid the extra cleaning that would otherwise be involved. Either of these practices requires that a recalibration of the instrument be made if accurate results are to be obtained.

If measurements have been made under one set of conditions and you merely wish to establish a reference point with the same material under new conditions, the following procedure will suffice:

1. Measure the material in both the old and new container and/or with the guard leg removed and in place. Be sure that the same spindle and speed are used and that the temperature of the material remains the same.
2. Note the new reading - this is the new reference point corresponding to the original value.

This procedure may be used in establishing control methods to be followed when the Viscometer is to be used for quality control purposes, and the operator is not concerned with the actual centipoise value of the material.

If your work requires that actual centipoise values be obtained, we suggest the following procedure if a different container is to be used or if you don't wish to use the guard leg:

- (1) Following the procedures outlined earlier in this chapter, measure the viscosity of a Newtonian fluid, using a standard container as specified in Section 3.3.4. Brookfield Viscosity Standards are highly recommended for this procedure. Perform this measurement carefully, as the accuracy of your end result depends upon it. Multiply the Viscometer reading by the appropriate Factor to determine the fluid's viscosity in centipoise.
- (2) Transfer the Standard to the container for which the Viscometer is to be calibrated. Ensure that the fluid temperature is the same as it was during Step (1).
- (3) Using the same spindle you intend to use for subsequent sample testing, measure viscosity of the Standard in the new container. Note the dial or display reading and speed, S1.
- (4) The new range of measurement is determined by this formula:

$$R1 = \frac{100\eta}{x}$$

Where R1 is the full-scale range of measurement under the new conditions;  $\eta$  is the viscosity of the Standard as measured in step (1); and x is the dial or display reading obtained in step (3).

- (5) To calculate the resulting new ranges when the same spindle is operated at different speeds under the new conditions, use this formula:

$$\frac{R1}{R2} = \frac{S2}{S1}$$

Where R1 is the range already established in Step (4) for RPM of S1, and S2 is the speed for which range R2 is to be determined.

- (6) The multiplying factor (f) for the new conditions can be determined by this formula:

$$f = \frac{R1}{100}$$

Where R1 is the range for the particular spindle and speed combination used, as determined in Step (4).

To calculate viscosity for a Dial Reading Viscometer, therefore, multiply the reading obtained on the Viscometer's 0-100 scale by f.

### 3.5 Viscometer Maintenance

Brookfield Viscometers are highly reliable, provided the instrument is handled properly. Most problems are readily detected by the Calibration Check in Section 3.3.9. To prevent potential problems, a few pointers are worth remembering:

(A) The forces to which the Viscometer responds are extremely small; the optimum performance of the instrument depends on the elimination of all unnecessary friction which may affect its sensitivity. This means cleanliness. Care must be taken to prevent dust, fumes, liquids, and other forms of contamination from entering the Viscometer housing. If it is necessary to use the instrument in such environments, use of the spindle extensions and/or purge fittings is recommended to minimize the entry of contaminants. More information on these accessories can be found in Section 2.1.14.

(B) Never place the instrument upside down with a fluid-coated spindle attached.

(C) Do not expose the Viscometer to ambient temperatures in excess of 40°C. When measuring samples at high temperatures, the use of spindle extensions or the Thermosel accessory is recommended.

(D) Avoid applying side- or down-thrust to the spindle coupling; this protects the pivot point and jewel bearing, which can be broken or dulled by rough treatment. Always lift the spindle coupling when attaching or removing a spindle. Do not strike the spindle against the sample container or otherwise apply side-thrust to it. Do not pull down on the spindle or spindle coupling.

(E) Do not drop or severely jar the instrument. The Brookfield Laboratory Stand provides a convenient, sturdy support. If the Viscometer is intended for portable use, it should be stored in its carrying case when not in use.

If the Viscometer is physically damaged or fails the Oscillation Test in Section 3.3.9, it should be returned for repair to Brookfield Engineering Laboratories or to the dealer from whom it was purchased.

The need for periodic preventative maintenance varies with the conditions of use. Under normal circumstances, a yearly service should be sufficient to keep the Viscometer in top working order. More severe use will necessitate more frequent service. The instrument should be returned to Brookfield or one of its dealers for this service.

### 3.6 Viscometer Troubleshooting

Specific fault diagnosis procedures are detailed in the instruction manual that is provided with each Viscometer. The chart below lists some of the more common problems that you may encounter while using your Viscometer, along with the probable causes and suggested cures.

#### Spindle Does Not Rotate

- Make sure the viscometer is plugged in.
- Check the voltage rating on your viscometer (115V, 220V): it must match the wall voltage.
- Make sure the power switch is in the ON position.
- Make sure the speed selection is set properly and securely at the desired speed.

#### Spindle Wobbles When Rotating or Looks Bent

- Make sure the spindle is tightened securely to the viscometer coupling.
- Check the straightness of all other spindles; replace them if bent.
- Inspect viscometer coupling and spindle coupling mating areas and threads for dirt: clean threads on spindle coupling with a 3/56-inch left-hand tap.
- Inspect threads for wear; if the threads are worn, the unit needs service.
- Check to see if spindles rotate eccentrically or wobble. There is an allowable runout of 1/32-inch in each direction (1/16-inch total) when measured horizontally from the bottom of the spindle rotating in air.

- Check to see if the viscometer coupling is bent; if so, the unit is in need of service.
- Check that the instrument is level. Be sure that the bubble is in the center of the target in the level indicator.

If you are continuing to experience problems with your viscometer, follow this diagnosis section to help isolate the potential problem.

#### Perform an Oscillation Check

- Remove the spindle and turn the motor OFF.
- Gently push up on the viscometer coupling.
- Turn the coupling until the red pointer reaches 5-10 on the Dial Viscometer or the torque readings reach 5-10% on the Digital Viscometer.
- Gently let go of the coupling.
- Watch the pointer swing freely and finally rest within  $\pm 0.2\%$  of zero on the Dial Viscometer or the torque reading returns to within  $\pm 0.2\%$  of zero on the Digital Viscometer.

If the pointer sticks or the torque reading does not return to zero, the unit is in need of service.

#### Perform a Calibration Check

- Verify spindle, speed and model selection
- Verify test parameters: temperature, container, volume, method.
- Perform a calibration check in accordance with the procedures from the viscometer operating manual
  - ◆ Verify tolerances are calculated correctly.
  - ◆ Verify calibration check procedures were followed exactly

If the unit is found to be out of tolerance, the unit is in need of service. Please contact Brookfield or an authorized dealer for service.

## CHAPTER 4

### 4.1 Coming to Grips with Rheology

Rheology is defined by Webster's Dictionary as "the study of the change in form and the flow of matter, embracing elasticity, viscosity, and plasticity." We concern ourselves in this chapter with viscosity, further defined as "the internal friction of a fluid, caused by molecular attraction, which makes it resist a tendency to flow." Your Brookfield Viscometer measures this friction, and therefore functions as a tool of rheology. The purpose of this chapter is to acquaint you with the different types of flow behavior and use of the

Brookfield Viscometer as a rheological instrument to enable you to conduct a detailed analysis of virtually any fluid. This information is useful to all Viscometer users, particularly those adhering to the Theoretical and Academic schools of thought on viscosity measurement.

### 4.2 Viscosity

Viscosity is the measure of the internal friction of a fluid. This friction becomes apparent when a layer of fluid is made to move in relation to another layer. The

greater the friction, the greater the amount of force required to cause this movement, which is called “shear.” Shearing occurs whenever the fluid is physically moved or distributed, as in pouring, spreading, spraying, mixing, etc. Highly viscous fluids, therefore, require more force to move than less viscous materials.

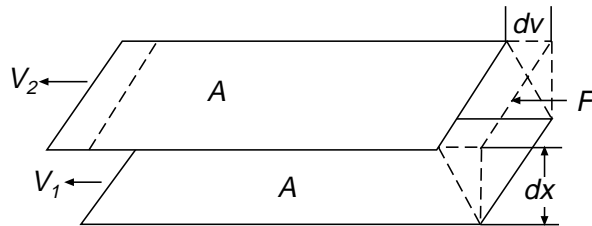

Figure 4-1

Isaac Newton defined viscosity by considering the model represented in Figure 4-1. Two parallel flat areas of fluid of the same size “A” are separated by a distance “dx” and are moving in the same direction at different velocities “V1” and “V2.” Newton assumed that the force required to maintain this difference in speed was proportional to the difference in speed through the liquid, or the velocity gradient. To express this, Newton wrote:

$$\frac{F}{A} = \eta \frac{dv}{dx}$$

where  $\eta$  is a constant for a given material and is called its “viscosity.”

The velocity gradient,  $\frac{dv}{dx}$ , is a measure of the change in speed at which the intermediate layers move with respect to each other. It describes the shearing the liquid experiences and is thus called “shear rate.” This will be symbolized as “ $\dot{\gamma}$ ” in subsequent discussions. Its unit of measure is called the “reciprocal second” ( $\text{sec}^{-1}$ ).

The term  $F/A$  indicates the force per unit area required to produce the shearing action. It is referred to as “shear stress” and will be symbolized by “ $\tau$ .” Its unit of measurement is “dynes per square centimeter” ( $\text{dynes/cm}^2$ ) or Newtons per square meter ( $\text{N/m}^2$ ).

Using these simplified terms, viscosity may be defined mathematically by this formula:

$$\eta = \text{viscosity} = \frac{\tau}{\dot{\gamma}} = \frac{\text{shear stress}}{\text{shear rate}}$$

The fundamental unit of viscosity measurement is “poise.” A material requiring a shear stress of one dyne per square centimeter to produce a shear rate of one reciprocal second has a viscosity of one poise, or 100 centipoise. You will encounter viscosity measurements expressed in “Pascal-seconds” ( $\text{Pa}\cdot\text{s}$ ) or “milli-Pascal-seconds” ( $\text{mPa}\cdot\text{s}$ ); these are units of the International System and are sometimes used in preference to the CGS designations. One Pascal-second is equal to ten poise; one milli-Pascal-second is equal to one centipoise.

Newton assumed that all materials have, at a given

temperature, a viscosity that is independent of the shear rate. In other words, twice the force would move the fluid twice as fast.

As we shall see, Newton was only partly right.

### 4.3 Newtonian Fluids

This type of flow behavior which Newton assumed for all fluids is called, not surprisingly, “Newtonian.” It is, however, only one of several types of flow behavior you may encounter. A Newtonian fluid is represented graphically in Figure 4-2. Graph A shows that the relationship between shear stress ( $\tau$ ) and shear rate ( $\dot{\gamma}$ ) is a straight line. Graph B shows that the fluid’s viscosity remains constant as the shear rate is varied. Typical Newtonian fluids include water and thin motor oils.

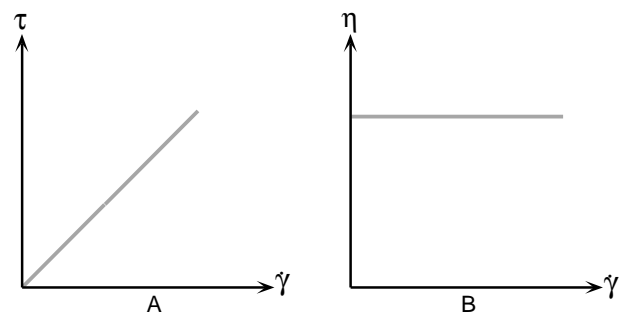

Figure 4-2

What this means in practice is that at a given temperature the viscosity of a Newtonian fluid will remain constant regardless of which Viscometer model, spindle or speed you use to measure it. Brookfield Viscosity Standards are Newtonian within the range of shear rates generated by Brookfield equipment. Newtonians are obviously the easiest fluids to measure - just grab your Viscometer and go to it. They are not, unfortunately, as common as that much more complex group of fluids, the non-Newtonians, which will be discussed in the next section.

### 4.4 Non-Newtonian Fluids

A non-Newtonian fluid is broadly defined as one for which the relationship  $\tau/\dot{\gamma}$  is not a constant. In other words, when the shear rate is varied, the shear stress doesn’t vary in the same proportion (or even necessarily in the same direction). The viscosity of such fluids will therefore change as the shear rate is varied. Thus, the experimental parameters of Viscometer model, spindle and speed all have an effect on the measured viscosity of a non-Newtonian fluid. This measured viscosity is called the “apparent viscosity” of the fluid and is accurate only when explicit experimental parameters are furnished and adhered to.

Non-Newtonian flow can be envisioned by thinking of any fluid as a mixture of molecules with different shapes and sizes. As they pass by each other, as

happens during flow, their size, shape, and cohesiveness will determine how much force is required to move them. At each specific rate of shear, the alignment may be different and more or less force may be required to maintain motion.

There are several types of non-Newtonian flow behavior, characterized by the way a fluid's viscosity changes in response to variations in shear rate. The most common types of non-Newtonian fluids you may encounter include:

**PSEUDOPLASTIC:** This type of fluid will display a decreasing viscosity with an increasing shear rate, as shown in Figure 4-3.

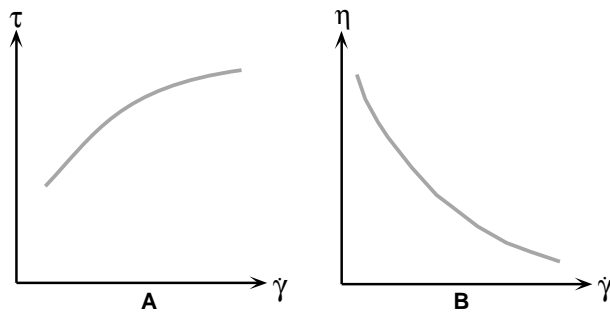

Figure 4-3

Probably the most common of the non-Newtonian fluids, pseudo-plastics include paints, emulsions, and dispersions of many types. This type of flow behavior is sometimes called "shear-thinning." An easily understood model is to imagine that in the moment of turning the spindle in the sample, the structure of molecules of the sample will be temporarily changed, and the molecule formation will be orientated more parallel to the spindle surface. So the hindering of the spindle rotation will decrease. The faster the rotation will become, the more the structure is destroyed and the less the structure of molecules slide in together, the lower the viscosity will be.

**DILATANT:** Increasing viscosity with an increase in shear rate characterizes the dilatant fluid; see Figure 4-4.

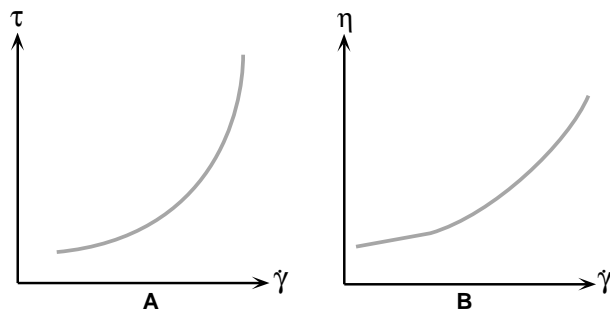

Figure 4-4

Although rarer than pseudoplasticity, dilatancy is frequently observed in fluids containing high levels of deflocculated solids, such as clay slurries, candy compounds, corn starch in water, and sand/water mixtures. Dilatancy is also referred to as "shear-thickening" flow behavior.

**PLASTIC:** This type of fluid will behave as a solid under static conditions. A certain amount of stress must be applied to the fluid before any flow is induced; this stress is called the "yield stress" ( $\tau'$ ). Tomato catsup is a good example of this type fluid; its yield value will often make it refuse to pour from the bottle until the bottle is shaken or struck, allowing the catsup to gush freely. Once the yield value is exceeded and flow begins, plastic fluids may display Newtonian, pseudoplastic, or dilatant flow characteristics. See Figure 4-5.

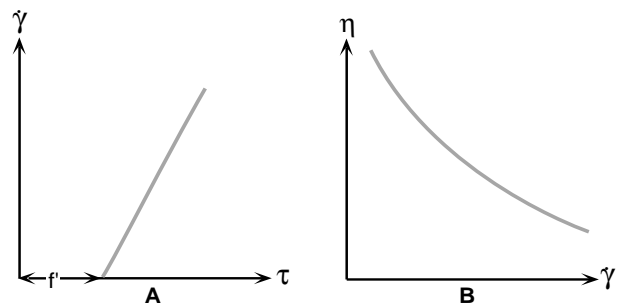

Figure 4-5

So far we have only discussed the effect of shear rate on non-Newtonian fluids. What happens when the element of time is considered? This question leads us to the examination of two more types of non-Newtonian flow: "thixotropic" and "rheopectic."

#### 4.5 Thixotropy and Rheopecty

Some fluids will display a change in viscosity with time under conditions of constant shear rate. There are two categories to consider:

**THIXOTROPY:** As shown in Figure 4-6, a thixotropic fluid undergoes a decrease in viscosity with time, while it is subjected to a constant shear rate.

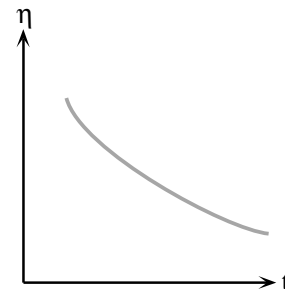

Figure 4-6

**RHEOPEXY:** This is essentially the opposite of thixotropic behavior, in that the fluid's viscosity increases with time as it is sheared at a constant rate. See Figure 4-7.

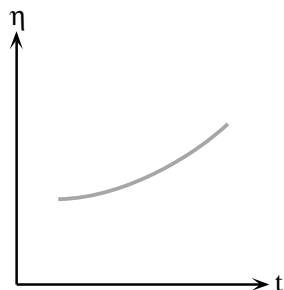

Figure 4-7

Both thixotropy and rheopexy may occur in combination with any of the previously discussed flow behaviors, or only at certain shear rates. The time element is extremely variable; under conditions of constant shear, some fluids will reach their final viscosity value in a few seconds, while others may take up to several days.

Rheopectic fluids are rarely encountered. Thixotropy, however, is frequently observed in materials such as greases, heavy printing inks, and paints.

When subjected to varying rates of shear, a thixotropic fluid will react as illustrated in Figure 4-8. A plot of shear stress versus shear rate was made as the shear rate was increased to a certain value, then immediately decreased to the starting point. Note that the "up" and "down" curves do not coincide. This "hysteresis loop" is caused by the decrease in the fluid's viscosity with increasing time of shearing. Such effects may or may not be reversible; some thixotropic fluids, if allowed to stand undisturbed for a while, will regain their initial viscosity, while others never will.

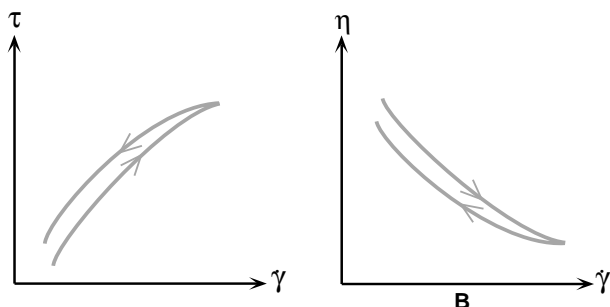

Figure 4-8

The rheological behavior of a fluid can, of course, have a profound effect on viscosity measurement technique. In Section 4.8 we will discuss some of these effects and ways of dealing with them. Chapter 5 will present advanced mathematical techniques used in analyzing flow behavior under a wide variety of conditions. First, however, we will discuss the effects of

laminar and turbulent flow on viscosity measurement.

#### 4.6 Laminar and Turbulent Flow

The very definition of viscosity implies the existence of what is called "laminar flow": the movement of one layer of fluid past another with no transfer of matter from one to the other. Viscosity is the friction between these layers.

Depending on a number of factors, there is a certain maximum speed at which one layer of fluid can move with relation to another, beyond which an actual transfer of mass occurs. This is called "turbulence." Molecules or larger particles jump from one layer to another and dissipate a substantial amount of energy in the process. The net result is that a larger energy input is required to maintain this turbulent flow than a laminar flow at the same velocity.

The increased energy input is manifested as an apparently greater shear stress than would be observed under laminar flow conditions at the same shear rate. This results in an erroneously high viscosity reading.

The point at which laminar flow evolves into turbulent flow depends on other factors besides the velocity at which the layers move. A material's viscosity and specific gravity as well as the geometry of the Viscometer spindle and sample container all influence the point at which this transition occurs.

Care should be taken to distinguish between turbulent flow conditions and dilatant flow behavior. In general, dilatant materials will show a steadily increasing viscosity with increasing shear rate; turbulent flow is characterized by a relatively sudden and substantial increase in viscosity above a certain shear rate. The material's flow behavior may be Newtonian or non-Newtonian below this point.

Due to the relatively low shear rates at which most Brookfield Viscometers operate, it is unlikely that you will encounter turbulent flow unless you are measuring viscosities lower than 15 cP with an LV series Viscometer or 85 cP with other models. The higher the viscosity of a fluid, the less likely it is to experience turbulence. If turbulence is observed while measuring low viscosity fluids, it can often be eliminated by using the UL Adapter accessory.

#### 4.7 Yield Behavior

Situation 1: medical ointment will not easily squeeze out of the tube when moderate pressure is applied.

Situation 2: salad dressing comes gushing out of the bottle with only a slight pressure squeeze.

The fundamental quality control problem plaguing both of the above products is a scientific term known as "yield stress". Simply put, this is the amount of force required to get a fluid to begin flowing. For tubes and squeeze bottles, this translates into how easily or how hard a customer must squeeze to get fluid to begin squirting or pouring out of the nozzle.

There are several ways to measure this yield stress

in products like ointments and salad dressings. Using a standard bench-top viscometer, the quality control technician can run an up/down speed ramp and record the torque values at each speed. We call this a “controlled rate” method. Using a ‘best fit’ line, typically available in standard software programs, the technician can back-calculate what the torque yield value would be. This type of calculation determines what is known as “dynamic yield” because the yield value has been interpolated.

A more precise method to determine yield is to use a controlled-stress rheometer such as the Brookfield R/S-CPS Rheometer. This type of instrument employs a controlled stress ramp to gradually increase the amount of force (torque) on the sample until flow is initiated. By using a controlled stress ramp, the QC technician can determine more directly where yield begins. This is known as “static yield”.

The type of spindle geometry used to obtain yield stress data is an important consideration. A practical, low-cost approach is to use standard disk or cylindrical spindles in a 600 mL beaker with a viscometer. This approach will employ a controlled rate test method as explained earlier. The use of coaxial cylinder or cone/plate geometry with either controlled rate or controlled stress mode of operation are strong alternatives. These geometries are typically considered to be more precise because the fluid is sheared evenly within a defined gap. The advantage of controlled stress over controlled rate is that this is a direct method for evaluating yield behavior. One disadvantage is that this type of instrumentation can be much more expensive than a standard controlled-rate, bench-top viscometer. The results, however, are generally considered to be more accurate. In addition, the amount of sample required to make the measurements can be minimized with these types of spindle systems.

In all of the above cases, the sample being tested experiences some handling prior to the start of the test. Therefore, there may be some adverse impact to the sample structure that could affect the test results. Specifying the step-by-step procedure for handling of the sample is very important.

An alternative spindle geometry, vane spindles, are suitable for most fluids and are ideal for paste-like materials, gels, fluids with suspended solids, and a variety of so-called “soft solid” materials (puddings, sauces). Certainly salad dressings fall into this latter category. The primary benefit of the vane spindle is that it imparts minimal disruption to the sample during spindle immersion. The spindle can be operated in either controlled rate or controlled stress mode, as explained above, to determine yield value.

The measurement of yield stress deserves to become a standard test method for quality control given the importance of assuring proper product behavior as illustrated in the examples at the beginning of this article. To simplify the burden on QC, one approach is to incorporate the QC test method for determining yield

value into a single purpose instrument, such as the Brookfield YR-1. This type of instrument, called a “yield rheometer”, costs roughly the same as a standard bench-top viscometer and provides the dedicated test capability to ensure that yield values are measured correctly. The firmware algorithm detects the maximum torque value and calculates the equivalent yield stress. In addition, the instrument has the ability to specify quality control limits between which the yield value must fall when making a measurement. This additional feature will save valuable time for the QC operator in making a pass/fail determination on the product prior to packaging.

The yield measurement capability found in the YR-1 has also been included in the DV-III Ultra Rheometer. This enables the DV-III Ultra to determine yield stress and then the flow curve (viscosity or shear stress vs. shear rate) for a sample material.

#### **4.8 What Affects the Rheological Property?**

Viscosity data often functions as a “window” through which other characteristics of a material may be observed. Viscosity is more easily measured than some of the properties that affect it, making it a valuable tool for material characterization. Earlier in this chapter we discussed various types of rheological behavior and how to identify them. Having identified a particular rheological behavior in a material, you may wonder what this information implies about its other characteristics. This section, based on information gleaned from years of customer experience, is intended as a “tickler” to get you thinking about the mysteries your Viscometer can help you solve. Keep always in mind if you compare two results in a measuring series: all parameters and all treatment must be kept the same.

##### **4.8.1 Temperature**

One of the most obvious factors that can have an effect on the rheological behavior of a material is temperature. Some materials are quite sensitive to temperature, and a relatively small variation will result in a significant change in viscosity. Others are relatively insensitive. Consideration of the effect of temperature on viscosity is essential in the evaluation of materials that will be subjected to temperature variations in use or processing, such as motor oils, greases, and hot-melt adhesives.

##### **4.8.2 Shear Rate**

Non-Newtonian fluids tend to be the rule rather than the exception in the real world, making an appreciation of the effects of shear rate a necessity for anyone engaged in the practical application of rheological data. It would, for example, be disastrous to try to pump a dilatant fluid through a system, only to have it go solid inside the pump, bringing the whole process to an abrupt halt. While this is an extreme example, the importance of shear rate effects should not be underestimated.

When a material is to be subjected to a variety of shear rates in processing or use, it is essential to know its viscosity at the projected shear rates. If these are not known, an estimate should be made. Viscosity measurements should then be made at shear rates as close as possible to the estimated values.

It is frequently impossible to approximate projected shear rate values during measurement because these values fall outside the shear rate range of the Viscometer. In this case, it is necessary to make measurements at several shear rates and extrapolate the data to the projected values. This is not the most accurate method for acquiring this information, but it is often the only alternative available, especially when the projected shear rates are very high. In fact, it is always advisable to make viscosity measurements at several shear rates to detect rheological behavior that may have an effect on processing or use. Where shear rate values are unknown or not important, a sample plot of viscosity versus RPM will often suffice.

Examples of materials that are subjected to, and are affected by, wide variations in shear rate during processing and use are: paints, cosmetics, liquid latex, coatings, certain food products, and blood in the human circulatory system. The following table shows typical examples of varying shear rates.

Situation	Typical range of shear rates (s <sup>-1</sup> )	Application
Sedimentation of fine powders in a suspending liquid	10 <sup>-6</sup> - 10 <sup>-4</sup>	Medicines, Paints
Levelling due to surface tension	10 <sup>-2</sup> - 10 <sup>-1</sup>	Paints, printing inks
Draining under gravity	10 <sup>-1</sup> - 10 <sup>1</sup>	Painting and coating, toilet bleaches
Extruders	10 <sup>0</sup> - 10 <sup>2</sup>	Polymers
Chewing and swallowing	10 <sup>1</sup> - 10 <sup>2</sup>	Foods
Dip coating	10 <sup>1</sup> - 10 <sup>2</sup>	Paints, confectionery
Mixing and stirring	10 <sup>1</sup> - 10 <sup>3</sup>	Manufacturing liquids
Pipe flow	10 <sup>0</sup> - 10 <sup>3</sup>	Pumping, blood flow
Rubbing	10 <sup>2</sup> - 10 <sup>4</sup>	Application of creams and lotions to the skin
Spraying and brushing	10 <sup>3</sup> - 10 <sup>5</sup>	Spray-drying, painting, fuel atomization
Milling pigments in fluid bases	10 <sup>3</sup> - 10 <sup>5</sup>	Paints, printing inks
High speed coating	10 <sup>5</sup> - 10 <sup>6</sup>	Paper
Lubrication	10 <sup>3</sup> - 10 <sup>7</sup>	Gasoline engines

#### 4.8.3 Measuring Conditions

The condition of a material during measurement of its viscosity can have a considerable effect on the results of such measurement. It is therefore important to be aware of, and to control as much as possible, the environment of any sample you are testing.

**First**, the viscosity measurement techniques outlined in Section 3.3 should be adhered to. Variables such as Viscometer model, spindle/speed combination, sample container size, absence or presence of the guard leg, sample temperature, sample preparation technique, etc., all affect not only the accuracy of your measurements, but the actual viscosity of the material you are measuring.

**Second**, other less obvious factors that may affect viscosity must be considered. For example, the sample material may be sensitive to the ambient atmosphere, as is the case with dental impression materials, blast furnace slag, blood and mucus. It may be that a controlled atmosphere favorable to the objectives of the test must be provided (see information on purge fittings in Section 2.14).

Another factor which may affect viscosity measurements is the homogeneity of the sample. It is usually desirable to have a homogeneous sample so that more consistent results may be obtained. Sometimes, however, tendency of a material to separate into non-homogeneous layers is the characteristic of most interest. Care must be taken in such instances not to disturb that which you wish to study by mixing or shaking the sample.

#### 4.8.4 Time

The time elapsed under conditions of shear obviously affects thixotropic and rheopectic (time-dependent) materials. But changes in the viscosity of many materials can occur over time even though the material is not being sheared. Aging phenomena must be considered when selecting and preparing samples for viscosity measurement. Consider also the fact that many materials will undergo changes in viscosity during the process of a chemical reaction, so that a viscosity measurement made at one time in the reaction may differ significantly from one made at another time.

#### 4.8.5 Pressure

Variations in pressure may cause: dissolved gases to form bubbles; entrained gases to change size as well as distribution, and in some cases, turbulence. Pressure is not experienced as often as other parameters. Pressure compresses fluids, and thus, increases intermolecular resistance. Liquids are compressible under the influence of very high pressures - similar to gases but to a much lesser extent. Increases of pressure tend to increase the viscosity. As an example: The flow properties of highly concentrated slurries (above 70-80% by vol-

ume of particles) where there is insufficient liquid to fill completely all the voids between the particles results in a three-phase mixture (i.e. solids, liquids, and usually air). Due to the presence of air, the mixture is compressible, and therefore, the more you compress it, the greater the resistance to flow.

#### **4.8.6 Previous History**

What has happened to a sample prior to a viscosity measurement can significantly affect the result, especially in fluids sensitive to heat or aging. Thus, storage conditions and sample preparation techniques must be designed to minimize their effect on subsequent viscosity tests. Thixotropic materials in particular are sensitive to prior history, as their viscosity will be affected by stirring, mixing, pouring, or any other activity which produces shear in the sample.

#### **4.8.7 Composition and Additives**

The composition of a material is a determining factor of its viscosity. When this composition is altered, either by changing the proportions of the component substances, or by the addition of other materials, a change in viscosity is quite likely. For example, the addition of solvent to printing ink reduces viscosity of the ink; and additives of many types are used to control the rheological properties of paints.

#### **4.8.8 Special Characteristics of Dispersions and Emulsions**

Dispersions and emulsions, which are multiphase materials consisting of one or more solid phases dispersed in a liquid phase, can be affected rheologically by a number of factors. In addition to many of the factors discussed previously, characteristics peculiar to multiphase materials are also significant to the rheology of such materials. These are discussed below.

One of the major characteristics to study is the state of aggregation of the sample material. Are the particles that make up the solid phase separate and distinct, or are they clumped together; how large are the clumps, and how tightly are they stuck together? If the clumps (flocs) occupy a large volume in the dispersion, viscosity of the dispersion will tend to be higher than if the floc volume was smaller. This is due to the greater force required to dissipate the solid component of the dispersion.

When flocs are aggregated in a dispersion, reaction of the aggregates to shear can result in shear-thinning (pseudoplastic) flow. At low shear rates, the aggregates may be deformed but remain essentially intact. As the shear rate is increased, the aggregates may be broken down into individual flocs, decreasing friction and therefore viscosity (For more information on pseudoplastic flow, see Section 4.4).

If the bonds within the aggregates are extremely strong, the system may display a yield value (see Section 4.4 about plastic flow). The magnitude of the yield value depends on the force required to break these bonds.

If a material's flocculated structure is destroyed with time as it is sheared, a time-dependent type of flow behavior will be observed (see Section 4.5).

If the shear rate is decreased after destruction of some or all of the flocculated structure, the material's viscosity may be lower than it previously was at the same shear rate. Since flocs begin to link together after destruction, the rate at which this occurs affects the time required for viscosity to attain previous levels. If the relinking rate is high, viscosity will be about the same as before. If the relinking rate is low, viscosity will be lower. This results in the rheological behavior called "thixotropy" (see Section 4.5).

The attraction between particles in a dispersed phase is largely dependent on the type of material present at the interface between the dispersed phase and the liquid phase. This in turn affects the rheological behavior of the system. Thus, the introduction of flocculating or deflocculating agents into a system is one method of controlling its rheology.

Shape of the particles making up the dispersed phase is also of significance in determining a system's rheology. Particles suspended in a flowing medium are constantly being rotated. If the particles are essentially spherical, rotation can occur freely. If, however, the particles are needle or plate-shaped, the ease with which rotation can occur is less predictable, as is the effect of varying shear rates.

The stability of a dispersed phase is particularly critical when measuring viscosity of a multiphase system. If the dispersed phase has a tendency to settle, producing a non-homogeneous fluid, the rheological characteristics of the system will change. In most cases, this means that the measured viscosity will decrease. Data acquired during such conditions will usually be erroneous, necessitating special precautions to ensure that the dispersed phase remains in suspension.

## CHAPTER 5

### 5.1 Advanced Methods for Rheological Analysis

As mentioned in Chapter 1, those who follow the Academic school of thought on viscosity measurement have more complex needs than those who follow the Pragmatic or "Theoretical" schools. They need viscosity data that are defined in rheological terms. This usually requires a complete mathematical description of the Viscometer's operating parameters and an analysis of the rheological behavior of the fluid being studied.

Previous chapters have described various types of fluid behavior and their relationship to measurements made with Brookfield Viscometers/Rheometers and accessories. The Appendix details the significant operating parameters of this equipment and presents simplified formulas for obtaining shear rate and shear stress values. However, for many this information is still inadequate to perform the type of analysis they require. Having identified a particular flow behavior and defined it mathematically, these people need more information to understand how the fluid will react in a certain situation, and how to control that reaction. It is for these people that this chapter is provided.

In it you will find basic formulas from which the simplified shear rate and shear stress information in the Appendix was derived. Also, various methods for analyzing Newtonian and non-Newtonian fluids are presented. The information presented here represents a cross-section of the most useful methods developed both by Brookfield Engineering Laboratories and by others. Other specific methods, usually applicable to a particular rheological problem, are sometimes available. Please inquire if you need more information.

### 5.2 Defining Operating Parameters of Various Spindle Geometries

In this section we present equations that define the operating parameters of spindle geometries found on various Brookfield Viscometers/Rheometers and accessories. These are organized according to the type of geometry being discussed. Definitions and values not listed may be found in the Appendix A.

#### 5.2.1 Cylindrical Spindles

The following equations apply to cylindrical spindles only, on any Brookfield Viscometer/Rheometer.

$$\text{SHEAR RATE (sec}^{-1}\text{): } \dot{\gamma} = \frac{2 \omega R_c^2 R_b^2}{x^2 (R_c^2 - R_b^2)} \quad (1)$$

$$\text{SHEAR STRESS (dynes/cm}^2\text{): } \tau = \frac{M}{2 \pi R_b^2 L} \quad (2)$$

$$\text{VISCOSITY (poise): } \eta = \frac{\tau}{\dot{\gamma}} \quad (3)$$

- Definitions:
- $\omega$  = angular velocity of spindle (rad/sec)  
[ =  $(\frac{2\pi}{60}) N$  ],  $N$  = RPM
  - $R_c$  = radius of container (cm)
  - $R_b$  = radius of spindle (cm)
  - $x$  = radius at which shear rate is being calculated (cm)
  - $M$  = torque input by instrument (dyne-cm)
  - $L$  = effective length of spindle (cm)  
(see Appendix A.4)

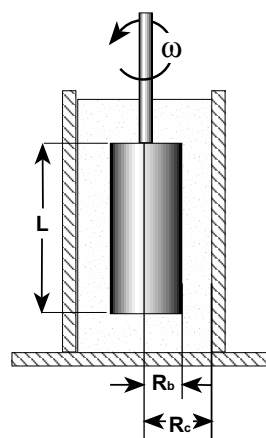

Note:  $R_c$  should not exceed  $2R_b$  for well defined shear rates.

### 5.2.2 Coaxial Cylinders

Coaxial cylinder geometry is found in the UL Adapter, Small Sample Adapter, Thermosel System, DIN Adapter, Spiral Adapter, PVS Rheometer and R/S Rheometer.

$$\text{SHEAR RATE (sec}^{-1}\text{): } \dot{\gamma} = \left( \frac{2R_c^2}{R_c^2 - R_b^2} \right) \omega \quad (4)$$

$$\text{SHEAR STRESS (dynes/cm}^2\text{): } \tau = \frac{M}{2 \pi R_b^2 L} \quad (5)$$

$$\text{VISCOSITY (poise): } \eta = \frac{\tau}{\dot{\gamma}} \quad (6)$$

Definitions:  $\dot{\gamma}$  = shear rate at surface of spindle (sec<sup>-1</sup>)

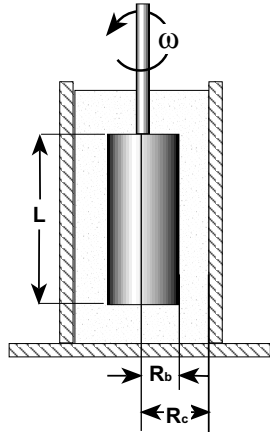

See Section 5.2.1 for other definitions

### 5.2.3 Cone and Plate

These equations may be used with all models of the Wells-Brookfield Cone/Plate Viscometer/Rheometer, CAP Viscometer/Rheometer and R/S-CPS Rheometer.

$$\text{SHEAR RATE (sec}^{-1}\text{): } \dot{\gamma} = \frac{\omega}{\sin \theta} \quad (7)$$

$$\text{SHEAR STRESS (dynes/cm}^2\text{): } \tau = \frac{M}{\frac{2}{3} \pi r^3} \quad (8)$$

$$\text{VISCOSITY (poise): } \eta = \frac{\tau}{\dot{\gamma}} \quad (9)$$

Definitions:  $\theta$  = cone angle (degrees)  
 $r$  = cone radius (cm)

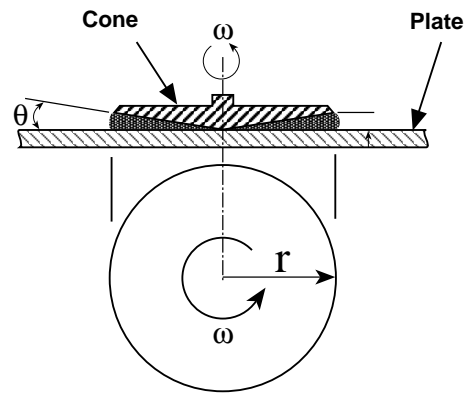

See Section 5.2.1 for definitions of other variables.

### 5.2.4 Disc and T-Bar Spindles

The standard disc-type spindles provided with most Viscometer models and the T-bar spindles used with the Helipath Stand accessory, as well as spindles with special shapes other than cylindrical or cone configurations, do not have directly definable shear rate and shear stress values. You may occasionally see the Viscometer's rotational speed referred to as a "shear rate," particularly when T-bar spindles are used. This is incorrect, as mathematical models are not available for calculating viscosity functions using T-bar spindles. However, models are available for the disc spindles. Refer to Technical Paper AR-82, available from Brookfield Engineering Laboratories.

### 5.2.5 Spiral Adapter Spindle

The Spiral Adapter has an inner, threaded spindle surrounded by a concentric outer cylinder.

This combination causes the sample to be continually pumped up through the Spiral Adapter chamber. The material reaches a steady state of flow during which viscosity is measured. The primary assumption is to think of the screw-shaped spindle as a cylinder rotating inside of the cylindrical chamber. The approximate shear rate in reciprocal seconds is .667N, where “N” is spindle speed in RPM.

### 5.2.6 “Paddle” / “Paste” Spindles

The Brookfield KU-1+ Viscometer uses a “paddle” spindle to measure the reaction torque when rotated at 200 RPM. Unlike “regular” viscometer spindles, the resultant viscosity is in KU (Kreb Units) and g (grams). Because of the unique spindle shape, no shear rate calculation is possible.

The Brookfield KU-2 Viscometer provides the same measurement capability as the KU-1+ and also converts the Krebs reading into a centipoise viscosity value. Since the spindle geometry is unique, the centipoise reading taken with the KU-2 does not correlate with centipoise measurements from a standard Brookfield Viscometer using disc or cylindrical spindles.

A paste spindle is available as an option to the paddle spindle. This spindle is similar to the paddle-type. The design consists of off-set rod-type vanes, approximately 22 mm x 19 mm long. The resultant viscosity is recorded in units of g (grams). It is suitable for use with high consistency materials such as roller mill pastes.

### 5.2.7 Vane Spindles

The vane spindle can be treated as a virtual cylinder with radius and length equal to the equivalent dimensions of a single vane. The equations in Section 5.2.1 may apply for low rotational speeds below 10 RPM. Eddy currents at higher rotational speeds could give falsely higher viscosity values.

### 5.2.8 Other Special Spindles

Brookfield can produce special spindles upon request. This activity is coordinated through the Sales Department at Brookfield. Spindles that have come out of this type of activity include modifications of the Helipath Stand T-bars (i.e. multiple tines), very large spindles for low viscosity liquids and special materials of construction.

## 5.3 Analyzing Time-Independent Non-Newtonian Fluids

The equations we have presented thus far will yield precisely defined viscosity data for both Newtonian and non-Newtonian fluids. With Newtonian fluids, this is all the analysis that is necessary, since variations in shear rate will have no effect on viscosity of the fluid.

When the fluid is non-Newtonian, however, the situation is more complicated. While the equations per-

mit complete definition of a reading made with a certain spindle at a certain speed, the numbers obtained with another spindle and/or speed will most likely be different. Which set of numbers is the ‘right’ one? Both, and neither! These differing numbers are part of the rheological description of the fluid, and therefore must be considered in the course of its analysis. In this section we will outline several methods for doing this on time-independent fluids as defined in Section 4.4.

### 5.3.1 Ratio Methods

A common method for characterizing and quantifying non-Newtonian flow is to figure the ratio of the fluid’s viscosity as measured at two different speeds (with the same spindle). These measurements are usually made at speeds that differ by a factor of 10 (for example, 2 and 20 RPM, 10 and 100 RPM, etc.), but any factor may be established.

In constructing the ratio, the viscosity value at the lower speed should be placed in the numerator, the one at the higher speed in the denominator. Therefore, for pseudoplastic (shear thinning) fluids, the ratio will exceed 1.0 as the degree of pseudoplastic behavior increases. Conversely, for dilatant (shear thickening) fluids, the ratio will be less than 1.0 as the degree of dilatancy increases.

This procedure is commonly known as the “thixotropic index.” The name is misleading since this ratio quantifies time-independent non-Newtonian behavior, not thixotropy, which is a time-dependent phenomenon. Analysis of time-dependent properties is detailed in Section 5.4.

A similar method eliminates calculation of viscosity and simply utilizes dial/display torque readings to derive what is known as a “viscosity ratio”:

$$\text{VISCOSITY RATIO} = -\log \left( \frac{M_x}{M_{10x}} \right) \quad (10)$$

Definitions:  $M_x$  = Viscometer torque reading at speed  $x$

$M_{10x}$  = Viscometer torque reading at speed  $10x$  (other ratios may be used)

### 5.3.2 Graphic Methods

The most basic graphic method of analyzing non-Newtonian flow is constructing a plot of viscosity versus spindle speed (using the same spindle for all readings.). Generally, viscosity is plotted along the Y-axis and speed (RPM) along the X-axis.

Slope and shape of the resulting curve will indicate the type and degree of flow behavior. For examples of this type graph, see the illustrations accompanying the discussion of non-Newtonian flow types in Section 4.4.

Another method is to plot Viscometer reading (on the X-axis) as a function of speed (on the Y-axis). If the graph is drawn on log-log paper, the result is frequently a straight line. When this hap-

pens, the slope of the line (indicating the type and degree of non-Newtonian flow) and its intercept with the X-axis (indicating its yield value, if any) can be used as empirical constants.

When shear rate and shear stress are known, as with cylindrical spindles or coaxial cylinder geometry, these values may be substituted for speed and Viscometer reading in the above methods. Thus, predictions of viscosity at other shear rates may be made by interpolating between or extrapolating beyond the values available with a particular spindle geometry.

When using these methods with disc spindle geometries, it is best to make all measurements with the same spindle. An assumption that can be made with regard to shear rate is that, for a given spindle, the shear rate is proportional to the speed. Therefore the shear rate at 30 RPM (for example) is 10 times the shear rate at 3 RPM.

### 5.3.3 Template Method

A more sophisticated technique for the analysis of non-Newtonian fluids involves use of a "template." Its use is limited to fluids that follow the "power law," meaning ones that display one type of non-Newtonian flow, rather than shifting from one type to another as shear rate is varied. For example, a material that changed from pseudoplastic to dilatant flow when a certain shear rate is exceeded would not follow the power law over the full range of shear rates measured.

The template method is usable only with data generated with cylindrical spindles or coaxial cylinders. The data is fitted to a template to determine a constant called the "STI." The STI is a convenient way to characterize non-Newtonian flow, much like the Viscosity Index. Certain parameters of the Viscometer in use and the STI are fitted to a second template, which is then used to predict the fluid's viscosity at any selected shear rate.

This is a useful method for predicting viscosity at shear rates not attainable by the Brookfield Viscometer, and for characterizing fluid behavior under a specific set of conditions. A complete description of the template method, including both templates, is available from Brookfield Engineering Laboratories as Technical Paper #AR-49.

### 5.3.4. Dynamic Yield Value Determination

Some fluids behave much like a solid at zero shear rate. They will not flow until a certain amount of force is applied, at which time they will revert to fluid behavior. This force is called the "yield value" and measuring it is often worthwhile. Yield values can help determine whether a pump has sufficient power to start in a flooded system, and often correlate with other properties of suspensions and emulsions. The pourability of a material is directly related to its yield value.

One method of determining yield value involves plotting Viscometer readings on the X-axis versus speed (RPM) on the Y-axis on standard graph paper. The line thus obtained is extrapolated to zero RPM. The corresponding value for the Viscometer reading represents the dynamic yield value. If a cylindrical spindle is used to make the readings, the yield value may be calculated from this equation:

$$\text{YIELD VALUE} \quad y = x1 \cdot fa \quad (11)$$

Definitions:  $y$  = yield value (dynes/cm<sup>2</sup>)  
 $x1$  = Viscometer reading @ 0 RPM  
 $fa$  = constant from table below

Cylindrical Spindle	Spindle Entry Code	Model			
		LV	RV	HA	HB
1	61	0.16	1.72	3.44	13.78
2	66	0.67	7.11	14.21	56.85
3	67	2.56	27.30	54.60	218.39
4	64	12.48	133.14	266.28	1065.14
5	65	25.26	269.45	538.91	2155.63

Extrapolating the line to zero RPM is easy if the line is fairly straight. This is called Bingham flow. If the line is curved, as in pseudoplastic or dilatant flow, an estimate of X1 must be made by continuing the curve until it intersects the X-axis (0 on the Y-axis). This estimated value of X1 is then subtracted from all the other readings that comprise the graph. These new values are plotted on log-log paper, Viscometer reading versus speed. This graph will usually be a straight line for power law fluids if the value for X1 was estimated accurately. A curved line on this graph indicates that another estimate of X1 should be made.

Once a straight line is obtained, the angle this line forms with the Y-axis (RPM) is measured. The power law index of this fluid can then be calculated from this equation:

$$\text{POWER LAW INDEX} \quad \bar{N} = \tan \theta \quad (12)$$

Definitions:  $\theta$  = Angle formed by plot line with Y-axis of graph

If  $\theta$  is less than 45 degrees, the fluid is pseudoplastic; greater than 45 degrees, dilatant.

The power law index can be used to calculate the effective shear rate at a given speed by using this equation:

$$\text{SHEAR RATE (sec}^{-1}\text{): } \gamma = \frac{\bar{N}}{(0.2095)N} \quad (13)$$

Definitions:  $\bar{N}$  = Power law index  
 $N$  = Viscometer speed (RPM)

Another method for determining yield value and plastic viscosity when a plot of Viscometer reading versus speed produces a curved line is to plot the square root of the shear stress versus the square root of the shear rate. This often straightens the line and facilitates extrapolation to zero shear rate. This method is most suitable for pseudoplastic fluids with a yield value conforming to a model of flow behavior known as the Casson equation. More information is available from Brookfield Engineering Laboratories in Technical Papers AR-77 and AR-79.

#### 5.4 Static Yield Value Determination

Newer instruments from Brookfield, such as the DV-III Ultra, R/S and YR-1 Rheometers, physically measure the start of flow at zero shear rate. These readings, measured in Pascals (Pa), dynes/cm<sup>2</sup> or Newton/m<sup>2</sup>, may differ from values obtained using dynamic methods (see preceding section), which back calculate yield stress from flow curve data (shear stress vs. shear rate).

#### 5.5 Analyzing Time-Dependent, Non-Newtonian Fluids

In most cases, analysis of thixotropic and rheopectic fluids (see Section 4.5) involves plotting changes in viscosity as a function of time. The simplest method is to select a spindle and speed (preferably a low speed) and leave the Viscometer running for an extended period, noting the dial or display reading at regular intervals. It is important to control temperature of the sample fluid carefully so that variations in temperature won't affect the results. A change in the fluid's viscosity over time indicates time-dependent behavior; a decrease signifies thixotropy, an increase rheopecty (or, in some cases, curing of the sample material).

A second method is to graph the Viscometer reading versus speed, using a single spindle. Starting at a low speed, note the reading at each successively higher speed until the reading goes off scale. A graph of these readings is the "up curve." Without stopping the Viscometer, reduce the speed incrementally to the starting point, again noting the reading at each speed. This is the "down curve." It is best to allow a consistent time interval between each speed change. If the fluid is time-independent, the "up curve" and the "down curve" will coincide. If they do not, the fluid is time-

dependent. Position of the "up curve" and the "down curve" indicates the type of flow behavior: if the "up curve" indicates a higher viscosity than the "down curve," the fluid is thixotropic; lower, rheopectic.

An indication of the recovery time of the fluid (how quickly it returns to its initial viscosity after exposure to shear conditions) can be obtained by turning off the Viscometer at the end of the "down curve," waiting for a given period of time, restarting the Viscometer and immediately taking a reading.

A more sophisticated approach is to calculate the "thixotropic breakdown coefficient." This is a single number which quantifies the degree of thixotropy (or rheopecty) displayed by the sample fluid. First, plot Viscometer reading (using a specified spindle/speed combination) versus log time, taking readings at regular intervals. This usually produces a straight line. Then, apply the following equation:

THIXOTROPY BREAKDOWN COEFFICIENT:

$$T_b = \left( \frac{St_1 - St_2}{\ln \left( \frac{t_2}{t_1} \right)} \right) \cdot F \quad (14)$$

Definitions:  $St_1$  = Viscometer reading at  $t_1$  minutes  
 $St_2$  = Viscometer reading at  $t_2$  minutes  
 $F$  = Factor for spindle/speed combination

Plots of thixotropic behavior may sometimes be used to predict the gel point of a fluid. One way to do this is to plot log Viscometer reading versus time, using a single spindle and speed. If the resulting line has a steep slope, gelling is likely to occur. If the line curves and flattens out, gelation is unlikely.

Another technique is to plot time versus the reciprocal of the Viscometer reading. In this method, the gel point can be read from the curve intercept at a Viscometer reading of 100. Fluids which do not gel will be asymptotic to the vertical axis.

#### 5.6 Temperature Dependence of Viscosity

The viscosity of most fluids decreases with an increase in temperature. By measuring viscosity at two temperatures (using a single spindle and speed), it is possible to predict a flow curve representing the temperature dependence of the viscosity of a fluid according to the following relationships using the application of simultaneous equations:

$$\eta = A \cdot e^{\left(\frac{B}{T}\right)} \quad (15)$$

$$\text{where } B = \left(\frac{T_1 \cdot T_2}{T_1 - T_2}\right) \cdot \ln\left(\frac{\eta_2}{\eta_1}\right)$$

$$A = \eta_1 \cdot e^{\left(\frac{-B}{T_1}\right)}$$

Definitions:  $T_1$  = Temperature at which viscosity  $\eta_1$  was measured  
 $T_2$  = Temperature at which viscosity  $\eta_2$  was measured

### 5.7 Math Models

The analysis of viscometer data may be enhanced through the use of mathematical models. Non-Newtonian behavior can be simply expressed through an equation, and in some cases, the coefficients of a model can be used to infer performance of a fluid under conditions of use.

Newtonian flow is defined by a proportional response in shear stress for a change in shear rate (a linear relationship). Non-Newtonian fluids will exhibit a non-linear stress/rate relationship. Newton's equation for viscosity has been modified many times to attempt to characterize non-Newtonian behavior. Some of the more widely used equations include Bingham, Casson, NCA/CMA Casson and Power Law.

#### Bingham

$$\tau = \tau_o + \eta \dot{\gamma}$$

#### Casson

$$\sqrt{\tau} = \sqrt{\tau_o} + \sqrt{\eta \dot{\gamma}}$$

#### NCA/CMA Casson

$$(1+a)\sqrt{\tau} = 2\sqrt{\tau_o} + (1+a)\sqrt{\eta \dot{\gamma}}$$

#### Power Law

$$\tau = k \dot{\gamma}^n$$

#### Herschel Bulkley

$$\tau = \tau_o + k \dot{\gamma}^n$$

where:  $\tau$  = shear stress

$\dot{\gamma}$  = shear rate

$\eta$  = viscosity

$\tau_o$  = yield stress

$k$  = consistency index

$n$  = flow index

$a$  = aspect ratio

The chocolate industry utilizes the NCA/CMA version of the Casson equation to evaluate chocolate prior

to final processing. This equation closely approximates the plastic behavior of chocolate. In addition, experience shows that the slope term, (plastic viscosity), indicates the chocolate's response to being moved in processing (mixing, pumping). Also, the "y" intercept, (yield stress or zero shear viscosity), indicates the force required to start/stop flowing (molding, enrobing). A particular batch of chocolate can be modified to achieve the specific performance characteristics required for the next processing step.

The oil drilling industry in the United States utilizes the power law equation to evaluate the performance of drilling mud and fracturing fluid. The latter is a material forced into a non-performing well to allow for additional oil recovery. The power law equation has been found to closely approximate its pseudoplastic behavior. In addition, experience shows that the power term ( $n$ , flow index) indicates the ability of the fluid to be moved down into the well. The coefficient ( $k$ , consistency index) indicates low shear rate flow behavior of the mud once it is at the far reaches of the well. A fracturing fluid can be modified in its storage vessel to obtain the appropriate flow characteristics prior to being pumped into the well.

In both cases described above, the successful use of the math model will prevent the utilization of improper fluid, and ultimately, poor performance or rejected material. The math model should be utilized as a tool to better understand and interpret viscometer data.

The utilization of math models normally requires viscosity data collection under defined conditions of shear rate and shear stress. Many spindle geometries are available for use with your Brookfield Viscometer/Rheometer which will provide shear stress and shear rate data. In addition, Brookfield offers several software packages and some instruments with the embedded capability to analyze data sets using a variety of mathematical models. Our brochure "Technical Papers on Viscosity Measurement and Control" lists available papers on specific application areas as well as general-interest experimental techniques. If you don't have the current edition, let us know and we'll send one to you. Ask for Data Sheet 091-C.

### 5.8 Brookfield Application Software

Brookfield offers various software programs which work in conjunction with viscometers/rheometers to allow for automatic data collection, analysis including use of math models and the creation of permanent test records:

Software	Instrument Required
RHEOCALC32	DV-III Ultra Rheometer
	DV-III+ Rheometer
	DV-II+ Pro Viscometer
WINGATHER32	DV-II+ Pro Viscometer
	DV-II+ Programmable Viscometer
	DV-II+ Viscometer
CAPCALC32	CAP+ series Viscometers
RHEOVISION	PVS Rheometer
RHEO 2000	R/S+ Rheometer

## 5.9 Miscellaneous Methods

There are many other techniques available for analyzing the rheological behavior of fluids under a variety of conditions. Space doesn't permit a detailed discussion here, but more information can be obtained from Brookfield Engineering Laboratories on these and other advanced methods:

- ◆ Approximation of shear rate and shear stress values using disc type spindles (AR-82).
- ◆ Techniques for determination of extremely low-shear viscosity and leveling behavior of coating materials using "spring relaxation" procedures (AR-84).
- ◆ Computer analysis of certain rheological characteristics.

## CHAPTER 6

The following methods provide various ways to obtain information on the viscosity behavior of your material using a Brookfield Viscometer or Rheometer. Choose the appropriate method to suit your requirements. Contact Brookfield or our authorized dealer if you require additional assistance.

### 6.1 Single Point Viscosity Test

- Choose a spindle.
- Select a rotational speed or shear rate.
- Control temperature if required.
- Specify how long the spindle rotates before making the measurement.
- Make sure the torque reading is > 10%.
- Record the viscosity value in cP or mPa•s.
- Record sample temperature in °F or °C.

### 6.2 Controlled Rate Ramp

- Choose a starting rotational speed or shear rate.
- Choose a maximum rotational speed or shear rate.
- Choose in-between speeds or shear rates as appropriate.
- Specify how long the spindle rotates before making the measurement.
- Record data at each speed or shear rate, similar to the method defined above in "SINGLE POINT".
- Try to keep the torque readings above 10%, if possible.

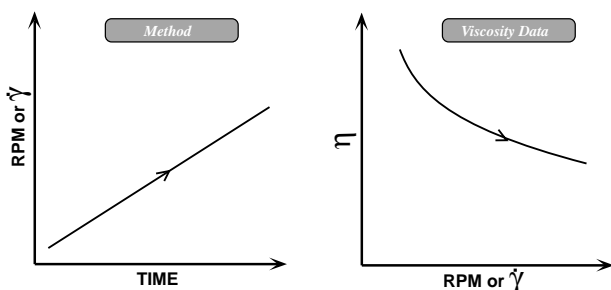

Figure 6-1

This method shows one example of how viscosity can change as a function of rotational speed or shear rate.

### 6.3 Up-Down Rate Ramp

- Use the same method defined above in "CONTROLLED RATE RAMP" to create the "UP RAMP". Upon reaching the maximum rotational speed or shear rate, reverse direction and return to the starting speed or shear rate. This creates the "DOWN RAMP".
- Record viscosity and torque data at each speed or shear rate.
- Try to keep the torque readings > 10% if possible.
- For each specific speed or shear rate, observe whether the viscosity value on the "UP RAMP" is different from the viscosity value on the "DOWN RAMP". Different viscosity values indicate that the material is "time sensitive" to shearing action.

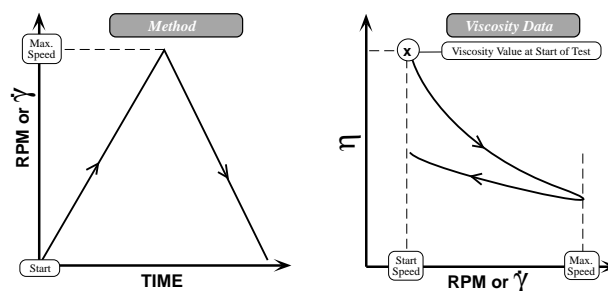

Figure 6-2

This method shows how viscosity can change as a function of both rotational speed/shear rate and time.

### 6.4 Time Sensitivity Test

- Choose a rotational speed or shear rate.
- Choose a time interval to record viscosity data.
- Observe whether the viscosity or torque values change as a function of time.

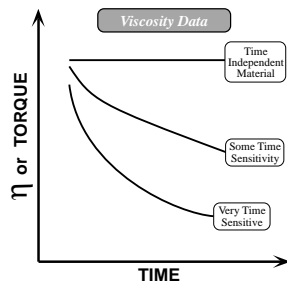

Figure 6-3

This method shows how sensitive the material is to being sheared at a fixed speed or shear rate.

### 6.5 Temperature Sensitivity Test

Choose a rotational speed or shear rate.  
 Choose a starting minimum temperature and a maximum temperature.  
 Record viscosity values at defined time intervals while the temperature ramps up.

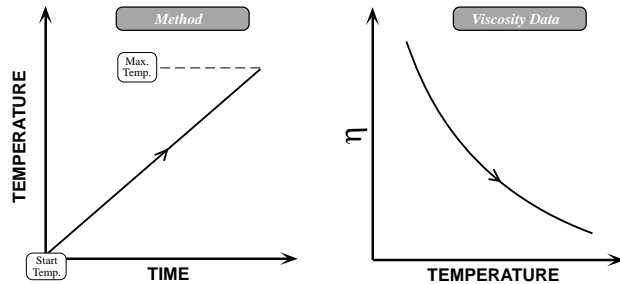

Figure 6-4

Most materials exhibit decreasing viscosity behavior with increasing temperature.

### 6.6 Temperature Profiling with Up-Down Rate Ramp Test

This method combines the approaches described in methods 6.3 and 6.5.  
 Choose specific temperatures of interest.  
 At each temperature, run the Up-Down ramp and record the viscosity data.

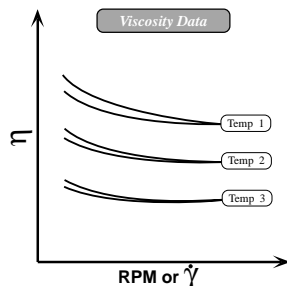

Figure 6-5

This method shows how viscosity can change as a function of temperature, time and rotational speed or shear rate.

### 6.7 Static Yield Test

Choose a vane spindle.  
 Choose a low rotational speed between .01 RPM and 0.5 RPM.  
 Record torque values at defined time intervals.  
 The maximum torque is an indication of the “static yield” value.  
 The maximum torque value will probably change if a different rotational speed is chosen.  
 This method is quick, easy to do, and may provide repeatable test data.

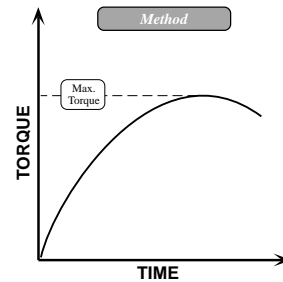

Figure 6-6

The maximum torque value can be converted into a yield stress value in Pascals or dynes/cm<sup>2</sup> using the formula provided with Brookfield vane spindles.

### 6.8 Dynamic Yield Test

Use coaxial cylinder or cone/plate spindle geometry.  
 Run a controlled rate ramp as defined in method 6.2. One suggestion is to use the lowest possible speeds for the controlled rate ramp.  
 Record the torque values or shear stress values at defined time intervals.  
 Review the data and determine a best fit straight line through the data.  
 The “dynamic yield” point is where the best fit straight line intersects the torque or shear stress axis.

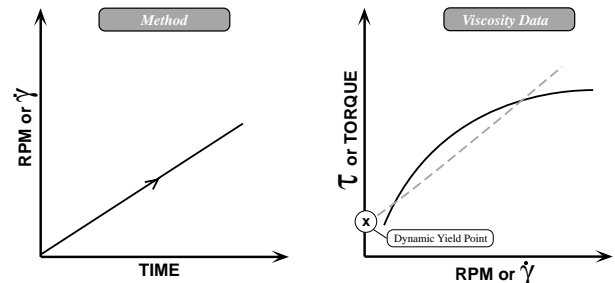

Figure 6-7

The dynamic yield stress value will probably be different from the static yield stress value.

## 6.9 Recovery

This parameter characterizes how rapidly a material returns to its original condition after it has been sheared.

Perform the time sensitivity test described in method 6.4. At the end of the time interval during which the material is sheared, set the rotational speed to 0 RPM.

Observe the torque signal to see what happens.

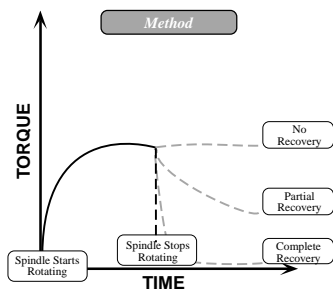

**Figure 6-8**

Some materials recover to their original condition within a very short time while others will recover only partially or not at all. This behavior is observed if, during the recovery period, the drive is decoupled from the spindle, as in the R/S-SST Rheometer. If a spring torque instrument is used such as a standard Brookfield LV/RV/HA/HB Viscometer or Rheometer, then the torque will decrease as the spring unwinds!

## APPENDIX A: Specifications, Ranges, and Operating Parameters

Appendix A is intended to provide the user of Brookfield Viscometers, Rheometers and accessories with all the information required to perform mathematical analyses of viscosity data acquired with this equipment. It includes essential dimensions, viscosity range tables and constants, organized by product in data sheet form. The following Brookfield Viscometers/Rheometers, Accessories, Special Purpose Instruments and High End Viscometers/Rheometers are covered:

### Standard Viscometers/Rheometers:

- A.1 Dial-Reading Viscometer
- A.2 Digital Viscometers/Rheometers
- A.3 Disc Spindles
- A.4 Cylindrical Spindles

### Standard Cone/Plate Viscometers/Rheometers:

- A.5 Wells-Brookfield Cone/Plate Viscometers/Rheometers

### Accessories for Standard Viscometers/Rheometers:

- A.6 Small Sample Adapter
- A.7 UL Adapter
- A.8 Thermosel System
- A.9 DIN Adapter
- A.10 Helipath Stand
- A.11 Spiral Adapter
- A.12 Vane Spindles

### Special Purpose Instruments:

- A.13 Krebs Viscometer
- A.14 YR-1 Rheometer
- A.15 CAP 1000+ Viscometer

### High End Viscometer/Rheometers:

- A.16 CAP2000+ Viscometer
- A.17 R/S Rheometer & R/S Soft Solids Tester
- A.18 PVS Rheometer

### Calibration Spring Torque for Standard Viscometers/Rheometers

Standard Brookfield Viscometers/Rheometers use a calibrated spiral spring inside the instrument to measure the resistance sensed by the spindle rotating in the fluid sample. The following table identifies the four common spring torques available from Brookfield:

LV	673.7 dyne-centimeters (full scale)
RV	7187.0 dyne-centimeters (full scale)
HA	14,374.0 dyne-centimeters (full scale)
HB	57,496.0 dyne-centimeters (full scale)

- Notes:
1. These values apply to all models with the same prefix designation: LV refers to LVF, LVT, LVTD, LVT-CP, LVTDCP, LVDV-I+, LVDV-II+, LVDV-II+ Programmable, LVDV-II+Pro, LVDV-III+, LVDV-III Ultra.
  2. For alternative spring torque models multiply the base spring torque by the multiplier in the model designation:  
 $5XLVT = 5 \times 673.7 = 3368.5$  dyne-centimeters (full scale).  
 $5XHB = 5 \times 57,496 = 287,500$  dyne-cm  
Multiplier also applies to all factors and ranges.
  3. Torque at any dial or display reading equals reading multiplied by full-scale torque divided by 100: RVT model, reading 40; torque =  $(40 \times 7187.0)/100 = 2874.8$  dyne-cm.
  4. To calculate the upper limit of viscosity measuring range (full scale range) for your instrument, multiply the factor by 100 after defining the spindle and speed in use. (see A.3, A.4) For digital models, push the autorange button.

**Some notes about the terms appearing in this Appendix:**

1. Shear rate constants (where given) are simply multiplied by the Viscometer's rotational speed (in RPM) to obtain the shear rate (in reciprocal seconds) for that speed. The constants are independent of Viscometer model, sample viscosity, or temperature.
2. Spindle Factors are listed as constants related to the Viscometers rotational speed. Spindle Factors are traditionally used to convert the torque value on a Dial Reading Viscometer to a centipoise value. Divide the given constant by the speed in use to obtain the Spindle Factor for that spindle/speed combination. This Spindle Factor is then multiplied by the Viscometer's dial reading to obtain viscosity (in centipoise).  
*For example:* the Spindle Factor for a #2 LV spindle on an LV Viscometer is given as 300/N (Section A.1.4). The Viscometer's rotational speed (RPM) is represented by N. If the measurement is being made at 12 RPM, the Spindle Factor is 300/12, or 25. Multiply all Dial Viscometer readings made with this spindle/speed combination by 25 to obtain viscosity in centipoise.
3. Where given, Sample Chamber Diameter refers to inside diameter (I.D.). Spindle Diameters are outside diameters (O.D.).
4. All dimensions are given in inches and in millimeters (in parentheses) unless otherwise noted. Be sure to use the metric values when required for rheological equations.

**A.1 Dial-Reading Viscometer Spindles and Speeds**

Model	No. of Spindles	No. of Speeds	Speeds (rpm)
LVF*	4	4	60, 30, 12, 6
LVT	4	8	60, 30, 12, 6, 3, 1.5, 0.6, 0.3
RVF*	7	4	20, 10, 4, 2
RVF-100*	7	4	100, 50, 20, 10
RVT, HAT, HBT	6	10	100, 50, 20, 10, 5, 4, 2.5, 2, 1, 0.5

\*This model is no longer available.

- Notes:
1. Speed variations (other than standard models listed above) are identified by suffix in model designation: RVT-200 fastest speed is 200 RPM. All other speeds are in same proportion as standard models: RVT-200 speeds are 200, 100, 40, 20, 10, 5, 2, 1 RPM.
  2. RPM specifications apply to all Viscometers with same model designation: LVT refers to LVT, LVT-D, LVT-CP, LVTDCP, etc. (each of these instruments has eight speeds as shown above for LVT model).
  3. Check with Brookfield or an authorized dealer regarding availability of non-standard calibration spring torques and rotational speeds.
  4. RVT, HAT, HBT Dial Reading Viscometers built before September 2001 have only eight speeds.
  5. RVT, HAT, HBT are supplied with six spindles as of September 2001. RV/H-1 spindle is available as an option.

## A.2 Digital Viscometers/Rheometers Spindles and Speeds

Current Viscometer/ Rheometer Model	No. of Spindles	No. of Speeds	Speeds (rpm)	Former Viscometer/ Rheometer Model
LVDV-E	4	18	100, 60, 50, 30, 20, 12, 10, 6, 5, 4, 3, 2.5, 2, 1.5, 1, .6, .5, .3	
RV/HA/HB DV-E	6*	18	100, 60, 50, 30, 20, 12, 10, 6, 5, 4, 3, 2.5, 2, 1.5, 1, .6, .5, .3	
LVDV-I+	4	18	100, 60, 50, 30, 20, 12, 10, 6, 5, 4, 3, 2.5, 2, 1.5, 1, .6, .5, .3	
RV/HA/HB DV-I+	6*	18	100, 60, 50, 30, 20, 12, 10, 6, 5, 4, 3, 2.5, 2, 1.5, 1, .6, .5, .3	
LVDV-II+ Pro	4	54	.01 to 200 rpm	LVDV-II+ Programmable, LVDV-II+, LVDV-II
RV/HA/HB DV-II+ Pro	6*	54	.01 to 200 rpm	RV/HA/HBDV-II+ Programmable, RV/HA/HBDV-II+, RV/HA/HBDV-II
LVDV-III Ultra	4	2,600	.01 to 250 rpm (.1 rpm increments from 0.1 to 250)	LVDV-III+, LVDV-III
RV/HA/HB DV-III Ultra	6*	2,600	.01 to 250 rpm (.1 rpm increments from 0.1 to 250)	RV/HA/HBDV-III+, RV/HA/HBDV-III

\*RV/H-1 Spindle is available as an option.

## A.3 Disc Spindle Information for Standard Viscometers/Rheometers

**Spindle Factors** are listed as constants related to the Viscometers rotational speed. Spindle Factors are traditionally used to convert the torque value on a Dial Reading Viscometer to a centipoise value. Divide the given constant by the speed in use to obtain the Spindle Factor for that spindle/speed combination. This Spindle Factor is then multiplied by the Viscometer's dial reading to obtain viscosity (in centipoise). *For example:* the Spindle Factor for a #2 LV spindle on an LV Viscometer is given as 300/N (see the following Disc Spindle Factors Table). The Viscometer's rotational speed (RPM) is represented by N. If the measurement is being made at 12 RPM, the Spindle Factor is 300/12, or 25. Multiply all Dial Viscometer readings made with this spindle/speed combination by 25 to obtain viscosity in centipoise.

### Disc Spindle Factors

Spindle	LV	RV	HA	HB
#2 LV	300/N*	—	—	—
#3 LV	1200/N	—	—	—
#1 RV/H	—	100/N	200/N	800/N
#2 RV/H	—	400/N	800/N	3200/N
#3 RV/H	—	1000/N	2000/N	8000/N
#4 RV/H	—	2000/N	4000/N	16M/N
#5 RV/H	—	4000/N	8000/N	32M/N
#6 RV/H	—	10M/N	20M/N	80M/N

\*N = RPM M = 1000

#1 RV/H-1 spindle is available as an option

## Disc Spindle Dimensions

Spindle	Figure	C-Diameter	D	E	F
#2 LV	1	.7370 (18.72)	.270(6.86)	1.000(25.4)	1.969 (50.0)
#3 LV	1	.4970 (12.6)	.070 (1.78)	1.007 (25.6)	1.969 (50.0)
#1 RV	2	2.2150 (56.26)	.885 (22.48)	1.062 (26.97)	2.406 (61.12)
#1 H	2	2.2150 (56.26)	.908 (23.06)	1.062 (26.97)	2.406 (61.12)
#2 RV	3	1.8477 (46.93)	.063 (1.65)	1.062 (26.97)	1.938 (49.21)
#2 H	3	1.8550 (47.12)	.063 (1.65)	1.062 (26.97)	1.938 (49.21)
#3 RV/H	3	1.3658 (34.69)	.063 (1.65)	1.062 (26.97)	1.938 (49.21)
#4 RV/H	3	1.0748 (27.3)	.063 (1.65)	1.062 (26.97)	1.938 (49.21)
#5 RV/H	3	.8324 (21.14)	.063 (1.65)	1.062 (26.97)	1.938 (49.21)
#6 RV/H	1	.5757 (14.62)	.063 (1.57)	1.188 (30.17)	1.938 (49.21)

Dimensions are in inches (mm). Dimension A is 4.531 (115) on LV spindles; 5.250 (133) on RV/H spindles. Dimension B is .125 (3.2) on all spindles.

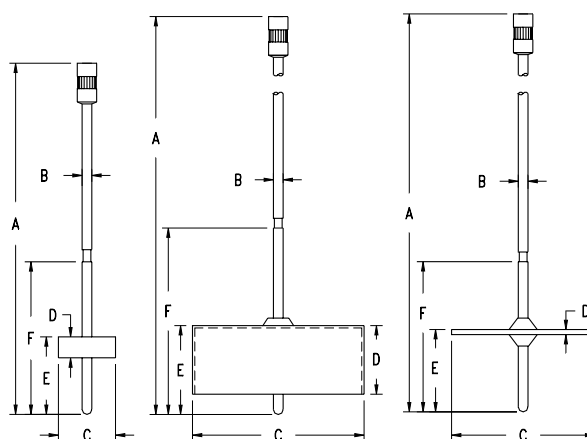

**Fig. 1**

**Fig. 2**

**Fig. 3**

### A.4 Cylindrical Spindles for Dial-Reading Viscometer and Digital Viscometers/Rheometers

Spindle Factors are listed as constants related to the Viscometers rotational speed. Spindle Factors are traditionally used to convert the torque value on a Dial Reading Viscometer to a centipoise value. Divide the given constant by the speed in use to obtain the Spindle Factor for that spindle/speed combination. This Spindle Factor is then multiplied by the Viscometer's dial reading to obtain viscosity (in centipoise).

For example: the Spindle Factor for a #1 LV spindle on an LV Viscometer is given as 72/N (see the following Cylindrical Spindle Factors and Shear Rates Table). The Viscometer's rotational speed (RPM) is represented by N. If the measurement is being made at 10 RPM, the Spindle Factor is 72/10, or 7.2. Multiply all Dial Viscometer readings made with this spindle/speed combination by 7.2 to obtain viscosity in centipoise.

Cylindrical Spindle Factors and Shear Rates

Spindle	LV	RV**	HA**	HB**	Shear Rate (sec <sup>-1</sup> )
#1 LV	**72/N	780/N	1560/N	6240/N	0.220N
#2LV CYL	**330/N	3350/N	6700/N	26.8M/N	0.212N
#3 LV CYL	1200/N	12.9M/N	25.8M/N	103.2M/N	0.210N
#4 LV	6000/N	64M/N	128M/N	512M/N	0.209N
#5 LV CYL +	12M/N	128M/N	256M/N	1024M/N	0.209N
#7 RV/H	3750/N	40M/N	80M/N	320M/N	0.209N

**N = RPM M = 1000 + = Optional Item**

**\*\*Factors are for readings made without using the guardleg.**

Cylindrical Spindle Dimensions

Spindle	Figure	C-Diameter	D	F
#1 LV	1	0.7418 (18.84)	2.563 (65.1)	3.188 (80.97)
#2 LV CYL	1	0.4037 (10.25)	2.124 (53.95)	2.624 (66.65)
#3 LV CYL	2	0.2315 (5.88)	1.688 (42.86)	2.094 (53.19)
#4 LV	3	0.1250 (3.2)	1.221 (31.01)	N/A
#5 LV	3	0.1250 (3.2)	0.536 (13.61)	N/A
#7 RV/H	3	0.1250 (3.2)	1.983 (50.37)	N/A

**Dimensions are in inches (mm). Dimension A is 4.531 (115) on LV spindles; 5.250 (133) on RV/H spindles. Dimension B is .125 (3.2) on all spindles.**

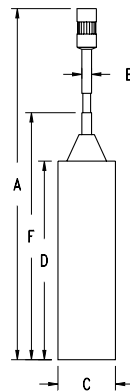

**Fig. 1**

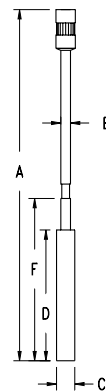

**Fig. 2**

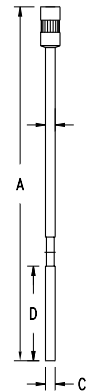

**Fig. 3**

### Cylindrical Spindle Equation

The following cylindrical spindle table depicts information for use with the equations presented in Section 5.2.1. only.

Spindle	Radius (cm) 1/2 C	Effective Length (cm)*	Actual Length (cm) D
#1 LV	0.9421	7.493	6.510
#2 LV CYL	0.5128	6.121	5.395
#3 LV CYL	0.2941	4.846	4.287
#4 LV	0.1588	3.396	3.101
#5 LV	0.1588	1.684	1.514
#7 RV	0.1588	5.620	5.037

\*Effective length includes correction for end effect and should be used in equations. Actual length is given for reference only.

### A.5 Wells-Brookfield Cone/Plate Viscometers/Rheometers

#### Cone Spindle Dimensions and Shear Rates

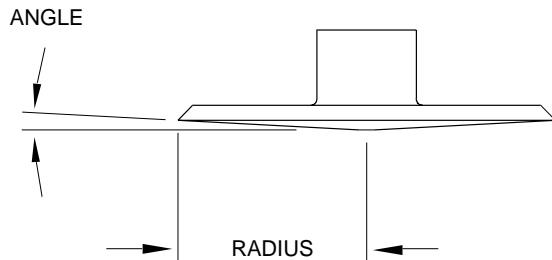

Cone Spindle	Angle (degrees)	Radius (cm)	Sample Size (mL)	Shear Rate (sec <sup>-1</sup> )
CP-40 / CPE-40	0.8	2.4	0.5	7.5N*
CP-41 / CPE-41	3.0	2.4	2.0	2.0N
CP-42 / CPE-42	1.565	2.4	1.0	3.84N
CP-51 / CPE-51	1.565	1.2	0.5	3.84N
CP-52 / CPE-52	3.0	1.2	0.5	2.0N

\*N = RPM

#### Cone Spindle Factors

Spindle Factors are listed as constants related to the Viscometers rotational speed. Spindle Factors are traditionally used to convert the torque value on a Dial Reading Viscometer to a centipoise value. Divide the given constant by the speed in use to obtain the Spindle Factor for that spindle/speed combination. This Spindle Factor is then multiplied by the Viscometer's dial reading to obtain viscosity (in centipoise). *For example:* the Spindle Factor for a CPE-40 spindle on an LV Viscometer is given as 3.07/N (see the following Cone Spindle Factors Table). The Viscometer's rotational speed (RPM) is represented by N. If the measurement is being made at 12 RPM, the Spindle Factor is 3.07/12, or 7.25. Multiply all Dial Viscometer readings made with this spindle/speed combination by 7.25 to obtain viscosity in centipoise.

Cone Spindle	LV	RV	HB	HA
CP-40 / CPE-40	3.07/N*	32.7/N	261.6/N	65.4/N
CP-41 / CPE-41	11.51/N	122.80/N	982.4/N	245.6/N
CP-42 / CPE-42	6.0/N	64.0/N	512.0/N	128.0/N
CP-51 / CPE-51	48.54/N	517.8/N	4142.4/N	1035.6/N
CP-52 / CPE-52	93.0/N	992.2/N	7937.60/N	1984.4/N

\*N = RPM

## ACCESSORIES FOR STANDARD VISCOMETERS/RHEOMETERS

### A.6 Small Sample Adapter

#### SC4 Series Spindle Factors and Shear Rates

Spindle Factors are listed as constants related to the Viscometers rotational speed. Spindle Factors are traditionally used to convert the torque value on a Dial Reading Viscometer to a centipoise value. Divide the given constant by the speed in use to obtain the Spindle Factor for that spindle/speed combination. This Spindle Factor is then multiplied by the Viscometer's dial reading to obtain viscosity (in centipoise). *For example:* the Spindle Factor for an SC4-21 spindle and 13R chamber on an RV Viscometer is given as 500/N (see the following SC4 Series Spindle Factors and Shear Rates Table). The Viscometer's rotational speed (RPM) is represented by N. If the measurement is being made at 20 RPM, the Spindle Factor is 500/20, or 25. Multiply all Dial Viscometer readings made with this spindle/speed combination by 25 to obtain viscosity in centipoise.

Spindle/ Chamber	Sample Size (mL)	LV	RV	HA	HB	Shear Rate (sec <sup>-1</sup> )
SC4-14/6R	2.1	1172/N	12.5M/N*	25M/N	100M/N	0.40N
SC4-15/7R	3.8	468.8/N	5000/N	10M/N	40M/N	0.48N
SC4-16/8R	4.2	1200/N	12.8M/N	25.6M/N	102.4M/N	0.29N
SC4-18/13R	6.7	30/N	320/N	640/N	2560/N	1.32N
SC4-21/13R	7.1	46.88/N	500/N	1000/N	4000/N	0.93N
SC4-25/13R	16.1	4800/N	51.2M/N	102.4M/N	409.6M/N	0.22N
SC4-27/13R	10.4	234.4/N	2500/N	5000/N	20M/N	0.34N
SC4-28/13R	11.0	468.8/N	5000/N	10M/N	40M/N	0.28N
SC4-29/13R	13.5	937.5/N	10M/N	20M/N	80M/N	0.25N
SC4-31/13R	9.0	300/N	3200/N	6400/N	25.6M/N	0.34N
SC4-34/13R	9.4	600/N	6400/N	12.8M/N	51.2M/N	0.28N

\*N = RPM    M = 1000

The values for the sample size (mL) were adjusted slightly in 2005. If unsure, check the fluid level in the chamber to verify that the spindle shaft is covered 1/8-inch above the point where the cone and shaft come together.

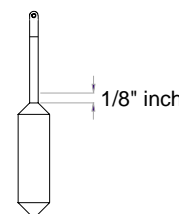

### SC4 Series Spindle Dimensions

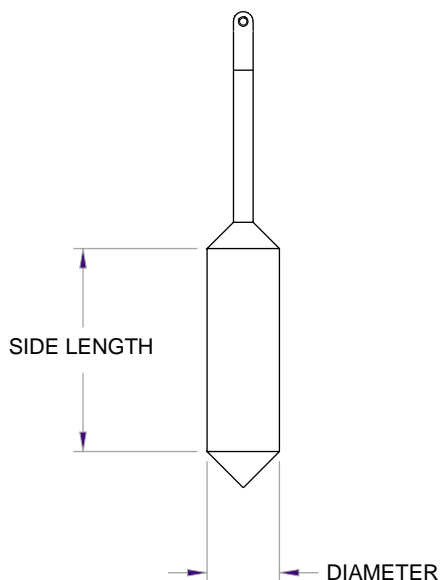

Spindle	Diameter inches (mm)	Side Length inches (mm)	Effective Length inches (mm) <sup>1</sup>
SC4-14	0.344 (8.74)	0.340 (8.64)	0.478 (12.14)
SC4-15	0.376 (9.55)	0.674 (17.12)	0.821 (20.85)
SC4-16	0.275 (6.99)	0.815 (20.70)	0.989 (25.12)
SC4-18	0.688 (17.48)	1.249 (31.72)	1.399 (35.53)
SC4-21/SD <sup>2</sup>	0.660 (16.77)	1.230 (31.24)	1.384 (35.15)
SC4-25	0.188 (4.78)	0.520 (13.21)	0.697 (17.70)
SC4-27/SD <sup>2</sup>	0.463 (11.76)	1.300 (33.02)	1.547 (39.29)
SC4-28	0.370 (9.39)	1.260 (32.00)	1.480 (37.59)
SC4-29	0.300 (7.62)	1.070 (27.18)	1.250 (31.75)
SC4-31	0.463 (11.76)	0.990 (25.15)	1.208 (30.68)
SC4-34	0.370 (9.39)	0.954 (24.23)	1.156 (29.36)

1. Refer to Section 5.2.1.
2. The "SD" designation indicates that the spindle is also available in a solid shaft configuration
3. DIN geometries for the Small Sample Adapter are also available. See Appendix A.9.

### SC4 Series Small Sample Chamber Dimensions

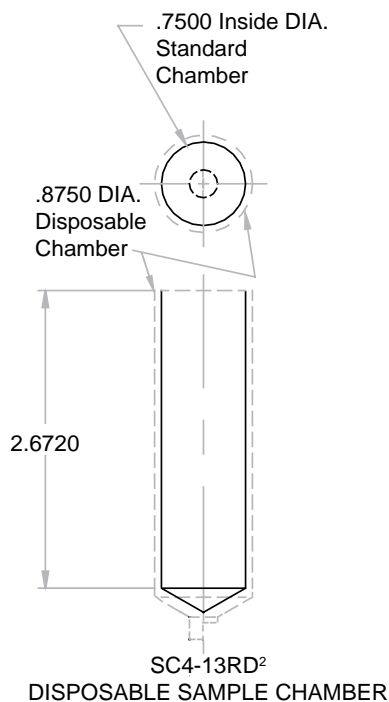

Chamber <sup>1</sup>	Diameter	Depth
SC4-6R/RP	0.500 (12.70)	1.110 (28.19)
SC4-7R/RP	0.501 (12.73)	1.745 (44.32)
SC4-8R/RP	0.515 (13.08)	1.584 (40.23)
SC4-13R/RP	0.750 (19.05)	2.550 (64.77)

Dimensions are in inches (mm).

1. The chamber is available with an optional embedded temperature probe, in which case the "RP" designation is used. E.g. SC4-6RP
2. Disposable chamber is available only in 13R size and comes in quantities of 100 chambers (Part No. SC4-13RD-100). Outside diameter is slightly larger than standard 13R chamber and requires special size water jacket (Part No. SC4-45YD) in order to use. Inside diameter and sample volume required are same as 13R chamber. Contact Brookfield or an authorized dealer for information.

## A.7 UL Adapter

### UL Adapter Spindle Factors and Shear Rates

Spindle Factors are listed as constants related to the Viscometers rotational speed. Spindle Factors are traditionally used to convert the torque value on a Dial Reading Viscometer to a centipoise value. Divide the given constant by the speed in use to obtain the Spindle Factor for that spindle/speed combination. This Spindle Factor is then multiplied by the Viscometer's dial reading to obtain viscosity (in centipoise). *For example:* the Spindle Factor for the UL spindle on an LV Viscometer is given as 6/N (see the following UL Adapter Spindle Factors and Shear Rates Table). The Viscometer's rotational speed (RPM) is represented by N. If the measurement is being made at 60 RPM, the Spindle Factor is 6/60, or 0.1. Multiply all Dial Viscometer readings made with this spindle/speed combination by 0.1 to obtain viscosity in centipoise.

	LV	RV	HA	HB	Shear Rate (sec <sup>-1</sup> )
UL	6/N*	64/N	128/N	512/N	1.224N
DIN-UL	11.44/N	122.N	244/N	976/N	1.29N

\*N = RPM Sample size 16.0 mL (end cap on).

### UL Adapter Dimensions

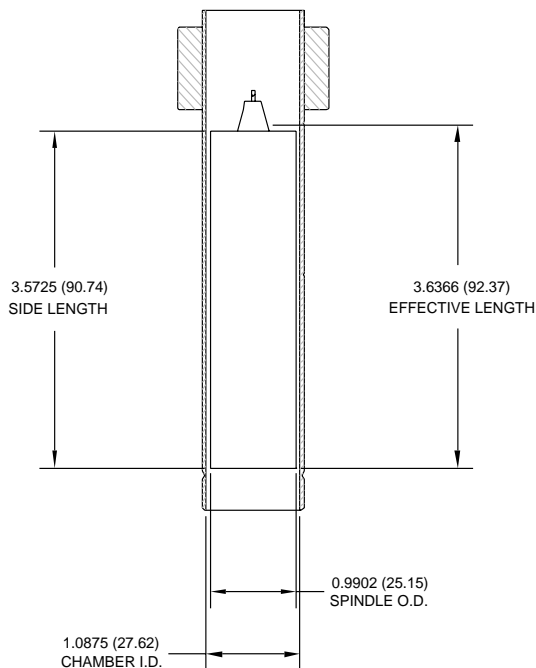

Spindle Effective Length*	Actual Length	Diameter	Chamber Inside Diameter
3.6366 (92.39)	3.5725 (90.74)	0.9902 (25.15)	1.0875 (27.62)

**Dimensions are in inches (mm).**

\*Effective length includes correction for end effect and should be used in manual calculations for shear rate/shear stress equations when using Dial Reading Viscometers. Actual length is given for reference only. Digital Viscometers/Rheometers have a correction factor built-in to the firmware of the instrument; no additional calculations are required.

## A.8 Thermosel System

### SC4 Series Spindle Factors and Shear Rates

Spindle Factors are listed as constants related to the Viscometers rotational speed. Spindle Factors are traditionally used to convert the torque value on a Dial Reading Viscometer to a centipoise value. Divide the given constant by the speed in use to obtain the Spindle Factor for that spindle/speed combination. This Spindle Factor is then multiplied by the Viscometer's dial reading to obtain viscosity (in centipoise).

*For example:* the Spindle Factor for the an SC4-27 spindle with 13R chamber on an RV Viscometer is given as 2500/N (the following SC4 Series Spindle Factors and Shear Rates Table). The Viscometer's rotational speed (RPM) is represented by N. If the measurement is being made at 50 RPM, the Spindle Factor is 2500/50, or 50. Multiply all Dial Viscometer readings made with this spindle/speed combination by 50 to obtain viscosity in centipoise.

Spindle <sup>1</sup>	Sample Size	LV	RV	HA	HB	Shear Rate (sec <sup>-1</sup> )
SC4-18	8.0	30/N*	320/N	640/N	2560/N	1.32N
SC4-21	8.0	46.88/N	500/N	1000/N	4000/N	0.93N
SC4-27/BS	10.5	234.4/N	2500/N	5000/N	20M/N	0.34N
SC4-28/BS	11.5	468.8/N	5000/N	10M/N	40M/N	0.28N
SC4-29/BS	13.0	937.5N	10M/N	20M/N	80M/N	0.25N
SC4-31/BS	10.0	300/N	3200/N	6400/N	25.6M/N	0.34N
SC4-34/BS	9.5	600/N	6400/N	12.8M/N	51.2M/N	0.28N

\*N = RPM    M = 1000

1. The "BS" designation indicates that the spindle is also available in a solid shaft configuration.
2. DIN geometry for the Thermosel is also available. See Appendix A.9.

### SC4 Series Spindle Dimensions

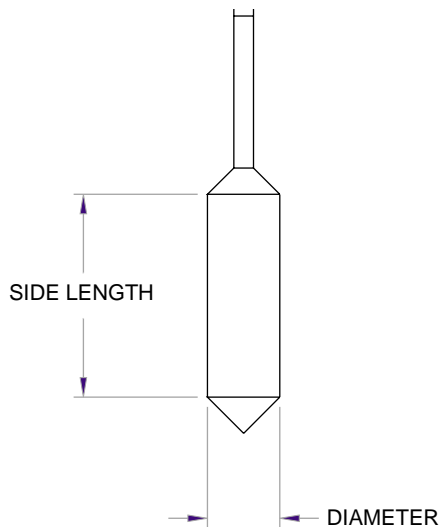

Spindle <sup>1</sup>	Diameter inches (mm)	Side Length inches (mm)	Effective Length inches (mm)*
SC4-18	0.688 (17.48)	1.249 (31.72)	1.399 (35.53)
SC4-21	0.660 (16.76)	1.230 (31.24)	1.384 (35.15)
SC4-27/BS	0.463 (11.76)	1.300 (33.02)	1.547 (39.29)
SC4-28/BS	0.370 (9.39)	1.260 (32.00)	1.480 (37.59)
SC4-29/BS	0.300 (7.62)	1.070 (27.18)	1.250 (31.75)
SC4-31/BS	0.463 (11.76)	0.990 (25.15)	1.208 (30.68)
SC4-34/BS	0.370 (9.39)	0.954 (24.23)	1.156 (29.36)

Dimensions are in inches (mm).

\*Refer to Section 5.2.1

1. The "BS" designation indicates that the spindle is also available in a solid shaft configuration.

## HT-2 Sample Chamber Dimensions

Diameter	Depth
0.750 (19.05)	3.062 (77.77)

Disposable HT-2DB chambers for use with Thermosel are available from Brookfield or an authorized dealer.

## A.9 DIN Adapter

### DIN Spindle Factors and Shear Rates

Spindle	LV	RV	HA	HB	Shear Rate
HT-DIN-81	34.2/N	365/N	730/N	2,920/N	1.29N
SC4-DIN-82	34.2/N	365/N	730/N	2,920/N	1.29N
SC4-DIN-83	113.4/N	1,213/N	2,426/N	9,704/N	1.29N
ULA-DIN-85	11.44/N	122/N	244/N	976/N	1.29N
ULA-DIN-86	34.2/N	365/N	730/N	2,920/N	1.29N
ULA-DIN-87	113.4/N	1,213/N	2,426/N	9,704/N	1.29N

**N=RPM**

### DIN Spindle Dimensions

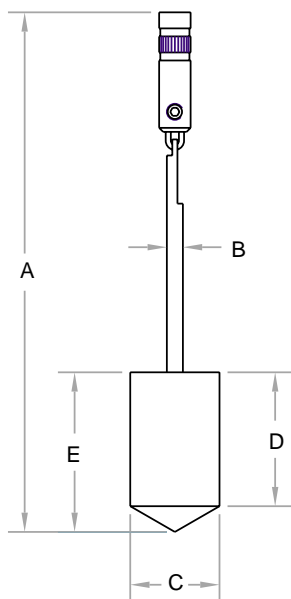

Spindle No.	A	B-Diameter	C-Diameter	D	E
HT-DIN-81	6.096 (154.84)	.125 (3.18)	.6915 (17.56)	1.0373 (26.35)	1.237 (31.42)
SC4-DIN-82	5.219 (132.56)	.125 (3.18)	.6915 (17.56)	1.0373 (26.35)	1.237 (31.42)
SC4-DIN-83	4.526 (114.96)	.125 (3.18)	.4617 (11.73)	.6926 (17.59)	.826 (20.98)
ULA-DIN-85	6.066 (154.08)	.125 (3.18)	1.0026 (25.47)	1.504 (38.2)	1.793 (45.54)
ULA-DIN-86	3.911 (99.34)	.125 (3.18)	.6952 (17.66)	1.0428 (26.49)	1.244 (31.6)
ULA-DIN-87	3.500 (88.9)	.125 (3.18)	.4654 (11.82)	.6981 (17.73)	.833 (21.16)

**Dimensions are in inches (mm)**

## DIN Chamber Dimensions

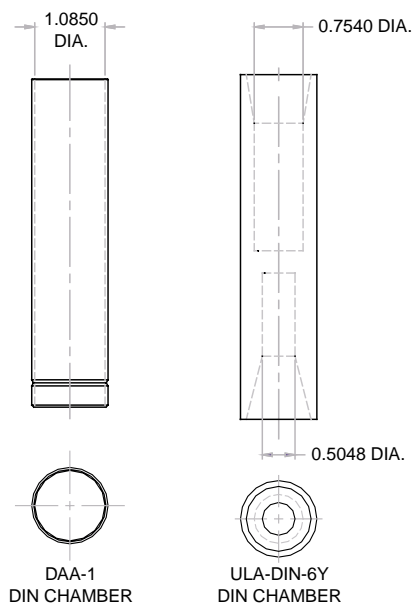

Spindle No.	Chamber No.	Chamber ID	Accessory Used With...
HT-DIN-81	HT-2	.7500 (19.05)	Thermosel
SC4-DIN-82	SC4-13R	.7500 (19.05)	Small Sample Adapter
SC4-DIN-83	SC4-7R	.500 (12.7)	Small Sample Adapter
ULA-DIN-85	DAA-1	1.0875 (27.62)	DIN Adapter
ULA-DIN-86	ULA-DIN-6Y	.7540 (19.15)	DIN Adapter
ULA-DIN-87	ULA-DIN-6Y	.5048 (12.82)	DIN Adapter

Dimensions are in inches (mm)

### A.10 Helipath Stand with T-Bar Spindles

#### T-Bar Spindle Factors

Spindle Factors are listed as constants related to the Viscometers rotational speed. Spindle Factors are traditionally used to convert the torque value on a Dial Reading Viscometer to a centipoise value. Divide the given constant by the speed in use to obtain the Spindle Factor for that spindle/speed combination. This Spindle Factor is then multiplied by the Viscometer's dial reading to obtain viscosity (in centipoise). *For example:* the Spindle Factor for a T-C spindle on an RV Viscometer is given as 10,000/N (see the following T-Bar Spindle Factors Table). The Viscometer's rotational speed (RPM) is represented by N. If the measurement is being made at 50 RPM, the Spindle Factor is 10,000/10, or 1,000. Multiply all Dial Viscometer readings made with this spindle/speed combination by 1,000 to obtain viscosity in centipoise.

**Maximum recommended rotational speed for spindle: 10-12 RPM.**

**Travel Speed for Helipath drive motor which moves rotating spindle downward into sample: 7/8 inch (22.2 mm) per minute.**

**There is no defined shear rate for T-bar spindles.**

Spindle	LV	RV	HA	HB
T-A	187.5/N*	2000/N	4000/N	16M/N
T-B	374.4/N	4000/N	8000/N	32M/N
T-C	936/N	10M/N	20M/N	80M/N
T-D	1872/N	20M/N	40M/N	160M/N
T-E	4680/N	50M/N	100M/N	400M/N
T-F	9360/N	100M/N	200M/N	800M/N

\*N = RPM      M = 1000

T-Bar Spindle Dimensions

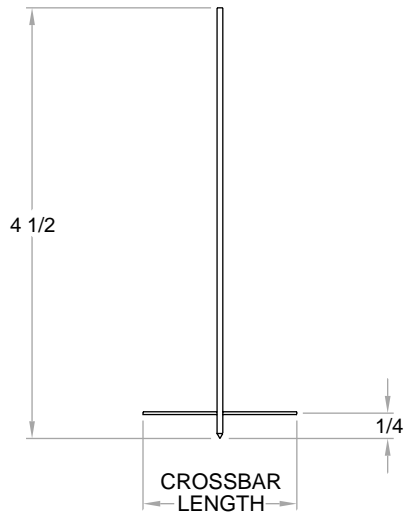

Spindle	Crossbar Length
T-A	1.894 (48.1)
T-B	1.435 (36.4)
T-C	1.065 (27.1)
T-D	0.804 (20.4)
T-E	0.604 (15.3)
T-F	0.403 (10.9)

Dimensions are in inches (mm)

**A.11 Spiral Adapter**

Spiral Spindle Factors and Shear Rate

Spindle Factors are listed as constants related to the Viscometers rotational speed. Spindle Factors are traditionally used to convert the torque value on a Dial Reading Viscometer to a centipoise value. Divide the given constant by the speed in use to obtain the Spindle Factor for that spindle/speed combination. This Spindle Factor is then multiplied by the Viscometer’s dial reading to obtain viscosity (in centipoise). *For example:* the Spindle Factor for a Spiral spindle on an RV Viscometer is given as 10,500/N (see the following Spiral Spindle Factors Table). The Viscometer’s rotational speed (RPM) is represented by N. If the measurement is being made at 30 RPM, the Spindle Factor is 10,500/30, or 350. Multiply all Dial Viscometer readings made with this spindle/speed combination by 350 to obtain viscosity in centipoise.

Spindle	LV	RV	HA	HB	Shear Rate
Spiral	984/N	10.5M/N	21M/N	84M/N	.667N

**N=RPM M=1,000**

Spiral Spindle Dimensions

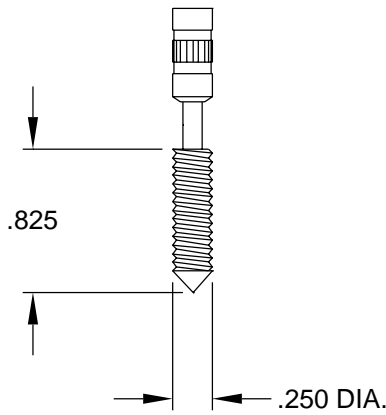

Spindle Diameter	Length
.250	.825

Spiral Chamber Dimensions

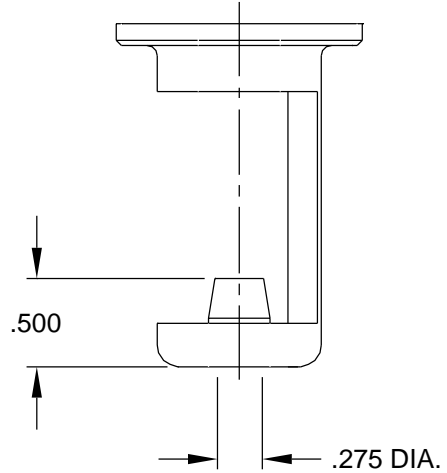

Diameter	Length
.275	.500

**A.12 Vane Spindles**

Vane Spindle Factors

Spindle Factors are listed as constants related to the Viscometers rotational speed. Spindle Factors are traditionally used to convert the torque value on a Dial Reading Viscometer to a centipoise value. Divide the given constant by the speed in use to obtain the Spindle Factor for that spindle/speed combination. This Spindle Factor is then multiplied by the Viscometer's dial reading to obtain viscosity (in centipoise). *For example:* the Spindle Factor for a V-72 spindle on an RV Viscometer is given as 1,100/N (see the following Vane Spindle Factors Table). The Viscometer's rotational speed (RPM) is represented by N. If the measurement is being made at 1,100 RPM, the Spindle Factor is 1,100/10, or 110. Multiply all Dial Viscometer readings made with this spindle/speed combination by 110 to obtain viscosity in centipoise.

Spindle	LV	RV	HA	HB
V-71	24.56/N	262/N	524/N	4.6M/N
V-72	104/N	1.11M/N	2.22M/N	8.88M/N
V-73	501/N	5.35M/N	10.7M/N	42.8M/N
V-74	5.09M/N	54.3M/N	108.6M/N	434.4M/N

**N=RPM M=1,000**

**Possibility of turbulence at speeds above 10 rpm may give artificially higher viscosity readings.**

Vane Spindle Dimensions

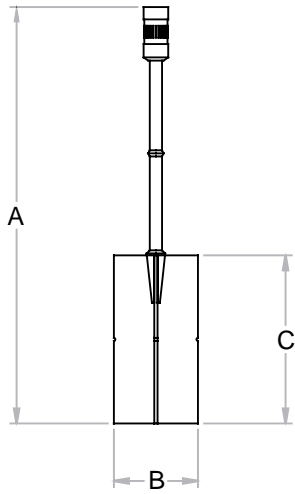

Spindle	Vane Length		Vane Diameter	
	inches	cm	inches	cm
V-71	2.708	6.878	1.354	3.439
V-72	1.708	4.338	.853	2.167
V-73	.998	2.535	.499	1.267
V-74	.463	1.176	.232	.589

Note: Sample container diameter should be twice (2x) the vane diameter when possible. Sample container depth should provide clearance at the bottom equivalent to vane spindle diameter when possible.

**SPECIAL PURPOSE INSTRUMENTS**

**A.13 KU-2 (Krebs) Viscometer**

Spindle Dimensions

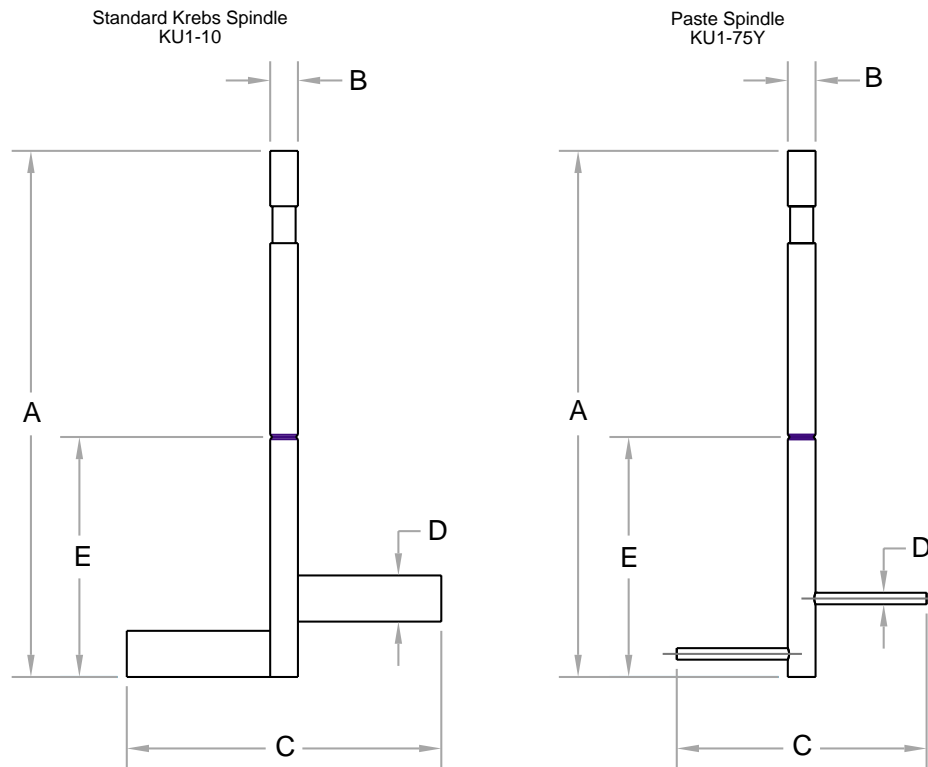

The KU-2 (KU-1+, KU-1) Viscometer measures viscosity in Krebs units and grams. The KU-2 Viscometer also reports the viscosity reading in centipoise. The measurement is made by rotating the spindle at 200 rpm.

Spindle No.	A	B-Diameter	C	D	E
KU1-10	3.562 (90.47)	.188 (4.77)	2.125 (53.98)	.312 (7.92)	1.625 (41.28)
KU1-75Y	3.562 (90.47)	.188 (4.77)	1.688 (42.88)	.078 (1.98)	1.625 (41.28)

**There is no defined shear rate for the Krebs and Paste Spindles.**

#### A.14 YR-1 Yield Stress Rheometer

The YR-1 uses a unique method to apply a controlled torque ramp to the vane spindle in order to measure yield stress behavior in the sample material. Standard torque ranges available for the YR-1 Rheometer are: 1/4RV, RV, HB, and 5xHB.

##### YR-1 Spindle Shear Stress Range Data

Spindle	Torque Range	Shear Stress Range	
		Pa	dyne/cm <sup>2</sup>
V-71	1/4RV	.125-1.25	1.25-12.5
V-72	1/4RV	.5-5	5-50
V-73	1/4RV	2.5-25	25-250
V-74	1/4RV	25-250	250-2500
V-71	RV	.5-5	5-50
V-72	RV	2-20	20-200
V-73	RV	10-100	100-1000
V-74	RV	100-1000	1000-10000
V-71	HB	4-40	40-400
V-72	HB	16-160	160-1600
V-73	HB	80-800	800-8000
V-74	HB	800-8000	8000-80000
V-71	5xHB	20-200	200-2000
V-72	5xHB	80-800	800-8000
V-73	5xHB	400-4000	4000-40000
V-74	5xHB	4000-40000	40000-400000

Note: 1 Pa = 10 dyne/cm<sup>2</sup>

##### Vane Spindle Dimensions

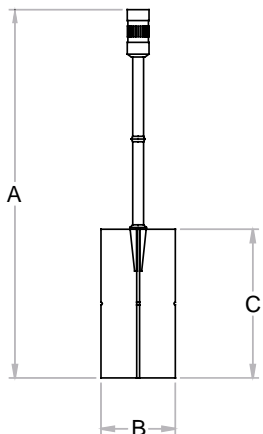

Spindle	Vane Length	Vane Diameter
V-71	2.708 in. / 6.878 cm	1.354 in. / 3.439 cm
V-72	1.708 in. / 4.338 cm	0.853 in. / 2.167 cm
V-73	0.998 in. / 2.535 cm	0.499 in. / 1.267 cm
V-74	0.463 in. / 1.176 cm	0.232 in. / 0.589 cm

## A.15 CAP 1000+ Viscometer

The CAP 1000+ Viscometer is a high-torque, single-speed cone/plate instrument used traditionally for testing at high shear rates around 10,000 sec<sup>-1</sup>. The CAP 1000+ can also be configured with lower torque range and choice of lower speed for special purpose applications.

Torque Range: Standard: 1xCAP or 181,000 dyne•cm  
Option: 1/23 CAP or 7,800 dyne•cm

Spindle	STANDARD SPEEDS		CHOICES FOR OPTIONAL SPEEDS			Shear Rate	Sample Volume	Cone Angle	Cone Radius
	Viscosity 750 RPM (Poise)	Viscosity 900 RPM (Poise)	Viscosity 5 RPM (Poise)	Viscosity 50 RPM (Poise)	Viscosity 500 RPM (Poise)				
CAP-S-01	0.25-2.5	0.2-2.0	37.5-375	3.75-37.5	0.375-3.75	13.3N sec <sup>-1</sup>	67 µL	0.45°	1.511cm
CAP-S-02	0.5-5	0.41-4.1	75-750	7.5-75	0.75-7.5	13.3N sec <sup>-1</sup>	38 µL	0.45°	1.200cm
CAP-S-03	1-10	0.83-8.3	150-1500	15-150	1.5-15	13.3N sec <sup>-1</sup>	24 µL	0.45°	0.953cm
CAP-S-04	2-20	1.67-16.7	300-3000	30-300	3-30	3.3N sec <sup>-1</sup>	134 µL	1.8°	1.200cm
CAP-S-05	4-40	3.33-33.3	600-6000	60-600	6-60	3.3N sec <sup>-1</sup>	67 µL	1.8°	0.953cm
CAP-S-06	10-100	8.3-83	1500-15000	150-1500	15-150	3.3N sec <sup>-1</sup>	30 µL	1.8°	0.702cm
CAP-S-07	N/A	N/A	62.5-625	6.25-62.5	N/A	2.0N sec <sup>-1</sup>	1700 µL	3.0°	2.399cm
CAP-S-08	N/A	N/A	250-2500	25-250	N/A	2.0N sec <sup>-1</sup>	400 µL	3.0°	1.511cm
CAP-S-09	N/A	N/A	1000-10000	100-1000	N/A	2.0N sec <sup>-1</sup>	100 µL	3.0°	0.953cm
CAP-S-10	0.67-6.7	0.5-5.0	100-1000	10-100	N/A	5.0N sec <sup>-1</sup>	170 µL	1.2°	1.511cm

N/A = Not appropriate for use at speeds above 400 rpm

### CAP Viscometer Spindle Dimensions

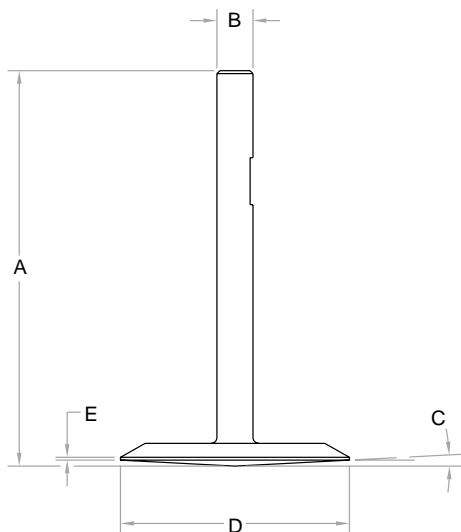

Spindle No.	A	B-Diameter	C-Angle	D-Diameter	E
CAP-S-01	2.075 (52.71)	.187 (4.75)	0° -27'	1.190 (30.23)	.010 (0.25)
CAP-S-02	2.075 (52.71)	.187 (4.75)	0° -27'	.945 (24.0)	.010 (0.25)
CAP-S-03	2.075 (52.71)	.187 (4.75)	0° -27'	.750 (19.05)	.010 (0.25)
CAP-S-04	2.075 (52.71)	.187 (4.75)	1° -48'	.945 (24.0)	.010 (0.25)
CAP-S-05	2.075 (52.71)	.187 (4.75)	1° -48'	.750 (19.05)	.010 (0.25)
CAP-S-06	2.075 (52.71)	.187 (4.75)	1° -48'	.553 (14.05)	.010 (0.25)
CAP-S-07	2.075 (52.71)	.187 (4.75)	3° -0'	1.889 (47.98)	.010 (0.25)
CAP-S-08	2.075 (52.71)	.187 (4.75)	3° -0'	1.190 (30.23)	.010 (0.25)
CAP-S-09	2.075 (52.71)	.187 (4.75)	3° -0'	.750 (19.05)	.010 (0.25)
CAP-S-10	2.075 (52.71)	.187 (4.75)	1° -12'	1.190 (30.23)	.010 (0.25)

## HIGH END VISCOMETERS/RHEOMETERS

### A.16 CAP 2000+ Viscometer

The CAP 2000+ Viscometer is a variable speed cone/plate instrument (5 rpm to 1000 rpm) with integrated temperature control.

Torque Range: Standard: 1xCAP or 181,000 dyne•cm  
Option: 1/23 CAP or 7,800 dyne•cm

See Section A.15 for spindle dimensions.

Spindle	Viscosity Min. Speed 5 RPM (Poise)	Viscosity Max. Speed 1000 RPM (Poise)	Shear Rate	Sample Volume	Cone Angle	Cone Radius
CAP-01	37.5-375	0.2-2.0	13.3N sec <sup>-1</sup>	67 µL	0.45°	1.511cm
CAP-02	75-750	0.4-4.0	13.3N sec <sup>-1</sup>	38 µL	0.45°	1.200cm
CAP-03	150-1500	0.8-8.0	13.3N sec <sup>-1</sup>	24 µL	0.45°	0.953cm
CAP-04	300-3000	1.0-10	3.3N sec <sup>-1</sup>	134 µL	1.8°	1.200cm
CAP-05	600-6000	3.0-30	3.3N sec <sup>-1</sup>	67 µL	1.8°	0.953cm
CAP-06	1500-15000	8.0-80	3.3N sec <sup>-1</sup>	30 µL	1.8°	0.702cm
CAP-07	62.5-625	0.35-3.5	2.0N sec <sup>-1</sup>	1700 µL	3.0°	2.399cm
CAP-08	250-2500	1.39-13.9	2.0N sec <sup>-1</sup>	400 µL	3.0°	1.511cm
CAP-09	1000-10000	5.56-55.6	2.0N sec <sup>-1</sup>	100 µL	3.0°	0.953cm
CAP-10	100-1000	0.58-5.8	5.0N sec <sup>-1</sup>	170 µL	1.2°	1.511cm

N/A = Not appropriate for use at speeds above 400 rpm

## A.17 R/S+ Rheometer & R/S+ Soft Solids Tester

The R/S+ Rheometer operates in either controlled stress or controlled rate mode. Controlled stress is useful for evaluation of yield behavior, creep analysis and viscoelastic response. Controlled rate provides flow curve information (viscosity vs. shear rate or shear stress). Available spindle geometries include cone/plate, plate/plate, coaxial cylinder and vane spindles (R/S+ Soft Solids Tester).

Spindle	Angle (Degrees)	Diameter (mm)	Sample Size (mL)	Max Shear Rate (sec <sup>-1</sup> )	Max Shear Stress (Pa)	Viscosity Range (cP)
<b>R/S-CPS+</b>						
<b>Cone</b>						
C25-1	1	25		6,000	12,223	300-600M
C25-2	2	25		3,000	12,223	500-3200M
C50-1	1	50		6,000	1,527	30-200M
C50-2	2	50		3,000	1,527	60-400M
C75-1	1	75	2.00	6,000	452	10-60M
C75-2	2	75	3.90	3,000	452	20-120M
<b>Plate</b>						
P25	Not Applicable	25	Variable	1,047	16,297	1.5M-9900M
P50	Not Applicable	50	Variable	2,094	2,037	90-200M
P75	Not Applicable	75	Variable	3,141	603	20-120M
<b>R/S Coaxial</b>						
CC-8		8		1,290	34,833	3.6M-3000M
CC-14		14	3.0	1,290	6,502	670-5000M
CC-25		25		1,290	1,141	120-80M
CC-45		45		1,290	195	20-150M
CC-48		48		5,100	206	5-32M
CC-DG		Double Gap	17.0	5,040	67	1-1000
<b>R/S-SST</b>						
<b>Vane</b>	<b>Length (mm)</b>	<b>Diameter (mm)</b>			<b>Max Shear Stress (Pa)</b>	
V80-40	80	40			213	
V40-20	40	20			1,706	
V30-15	30	15			4,042	

M=1000

## A.18 PVS Rheometer

The PVS Rheometer is a variable-speed, co-axial cylinder geometry instrument with the capability to pressurize the sample up to 1000 psi. “Stator” might also be called “bob” or “spindle.” On the PVS Rheometer, the “cup” (also called “chamber”) rotates while the stator remains stationary and senses torque.

### Viscosity Ranges and Shear Rates

Bob/ Stator No.	Viscosity Range cP (mPa• s)	Shear Rate (sec <sup>-1</sup> )	Sample Volume (mL)	Vapor Volume (mL)
B1	1-3M	1.7N	30	90
B2	20-36M	0.38N	53	90
B5	5-9M	0.85N	40	90
TA5B5	.5-1M	0.85N	150	90

**N=RPM M=1000**

### Dimensions

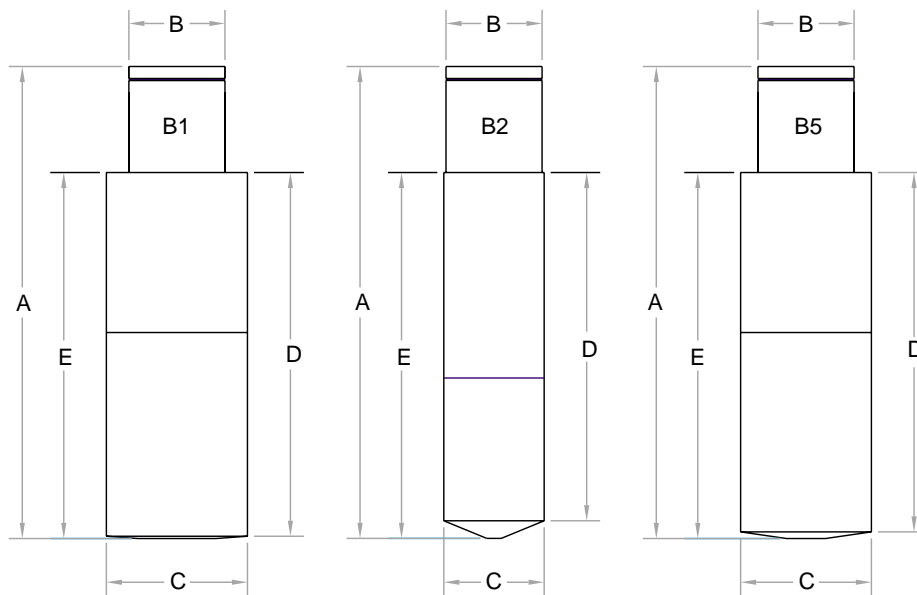

Stator No.	A inches (mm)	B-Diameter inches (mm)	C-Diameter inches (mm)	D inches (mm)	E inches (mm)	Shear Rate**	Cup Diameter** inches (mm)	Annulus** inches (mm)
B1	4.527 (114.99)	.925 (23.5)	1.358 (34.49)	3.507 (89.08)	3.527 (89.59)	1.703N*	1.45 (36.83)	0.046 (1.168)
B2	4.524 (114.91)	.925 (23.5)	.967 (24.56)	3.354 (85.19)	3.524 (89.51)	0.377N*	1.45 (36.83)	0.241 (6.135)
B5	4.526(114.96)	.925 (23.5)	1.259 (31.98)	3.462 (87.93)	3.526 (89.56)	0.85N*	1.45 (36.83)	0.095 (2.425)

\*N = RPM

\*\*Based on PVS-30 (HC) standard cup. Larger cup is available.

Optional Stator/Cup Geometry TA5 Used for Low Viscosity Fluids

Triple Annulus Dimensions

<b>Outer Annulus</b>	2.44 (61.98) ID x 2.12 (53.85) OD
<b>Intermediate Annulus</b>	1.99 (50.55) ID x 1.73 (43.94) OD
<b>Inner Annulus</b>	1.45 (36.83) ID x 1.259 (31.98) OD

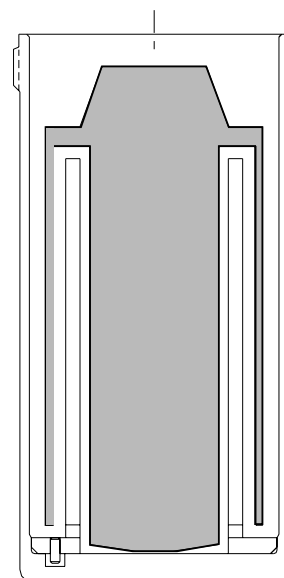

**Shaded area depicts Stationary Stator, Skirt and Cup**

## APPENDIX B: Spindle Entry Codes and Range Coefficients

The Range Coefficient is a convenient tool for quickly determining the maximum viscosity that can be measured with a specific spindle/speed combination. Identify the spindle in use and the torque range (LV, RV, HA, HB) of the Viscometer/Rheometer. Look up the Range Coefficient in the following table. Divide the Range Coefficient by the spindle speed to determine the maximum viscosity in centipoise that can be measured.

E.g. RV Viscometer with RV3 spindle: Range Coefficient is 100,000. At 50 rpm, the maximum viscosity that can be measured is 100,000/50 or 2,000 cP,

The Entry Code is the two digit number used to identify the spindle in use when operating a standard digital Viscometer/Rheometer.

Spindle	Entry Code	LV	RV	HA	HB
RV1	01	937	10,000	20,000	80,000
RV2	02	3,750	40,000	80,000	320,000
RV3	03	9,375	100,000	200,000	800,000
RV4	04	18,750	200,000	400,000	1,600,000
RV5	05	37,500	400,000	800,000	3,200,000
RV6	06	93,750	1,000,000	2,000,000	8,000,000
RV7	07	375,000	4,000,000	8,000,000	32,000,000
<b>HA</b>					
HA1	01	937	10,000	20,000	80,000
HA2	02	3,750	40,000	80,000	320,000
HA3	03	9,375	100,000	200,000	800,000
HA4	04	18,750	200,000	400,000	1,600,000
HA5	05	37,500	400,000	800,000	3,200,000
HA6	06	93,750	1,000,000	2,000,000	8,000,000
HA7	07	375,000	4,000,000	8,000,000	32,000,000
<b>HB</b>					
HB1	01	937	10,000	20,000	80,000
HB2	02	3,750	40,000	80,000	320,000
HB3	03	9,375	100,000	200,000	800,000
HB4	04	18,750	200,000	400,000	1,600,000
HB5	05	37,500	400,000	800,000	3,200,000
HB6	06	93,750	1,000,000	2,000,000	8,000,000
HB7	07	375,000	4,000,000	8,000,000	32,000,000
<b>LV</b>					
LV1	61	6,000	64,000	128,000	512,000
LV2	62	30,000	320,000	640,000	2,560,000
LV3	63	120,000	1,280,000	2,560,000	10,240,000
LV4	64	600,000	6,400,000	12,800,000	51,200,000
LV5	65	1,200,000	12,800,000	25,600,000	102,400,000
<b>LV-2C</b>					
LV-2C	66	30,000	320,000	640,000	2,560,000
<b>LV-3C</b>					
LV-3C	67	120,000	1,280,000	2,560,000	10,240,000

(Table continued on next page)

<b>Spindle</b>	<b>Entry Code</b>	<b>LV</b>	<b>RV</b>	<b>HA</b>	<b>HB</b>
T-A	91	18,750	200,000	400,000	1,600,000
T-B	92	37,440	400,000	800,000	3,200,000
T-C	93	93,600	1,000,000	2,000,000	8,000,000
T-D	94	187,200	2,000,000	4,000,000	16,000,000
T-E	95	468,000	5,000,000	10,000,000	40,000,000
T-F	96	936,000	10,000,000	20,000,000	80,000,000
Spiral	70	98,400	1,050,000	2,100,000	8,400,000
DIN-81	81	3,470	37,000	74,000	296,000
DIN-82	82	3,520	37,500	75,000	300,000
DIN-83	83	11,330	120,900	241,800	967,200
ULA	00	600	6,400	12,800	51,200
ULA-DIN-81	81	3,420	36,500	73,000	292,000
ULA-DIN-82	82	3,420	36,500	73,000	292,000
ULA-DIN-83	83	11,340	121,300	242,600	970,400
ULA-DIN-85	85	1,144	12,200	24,400	97,600
ULA-DIN-86	86	3,420	36,500	73,000	292,000
ULA-DIN-87	87	11,340	121,300	242,600	970,400
SC4-14/6R	14	117,200	1,250,000	2,500,000	10,000,000
SC4-15/7R	15	46,880	500,000	1,000,000	4,000,000
SC4-16/8R	16	120,000	1,280,000	2,560,000	10,240,000
SC4-18/13R	18	3,000	32,000	64,000	256,000
SC4-21/13R	21	4,688	50,000	100,000	400,000
SC4-25/13R	25	480,000	5,120,000	10,240,000	40,960,000
SC4-27/13R	27	23,440	250,000	500,000	2,000,000
SC4-28/13R	28	46,880	500,000	1,000,000	4,000,000
SC4-29/13R	29	93,750	1,000,000	2,000,000	8,000,000
SC4-31/13R	31	30,000	320,000	640,000	2,560,000
SC4-34/13R	34	60,000	640,000	1,280,000	5,120,000
CPE-40/CP-40	40	307	3,270	6,540	26,160
CPE-41/CP-41	41	1,151	12,280	24,560	98,240
CPE-42/CP-42	42	600	6,400	12,800	51,200
CPE-51/CP-51	51	4,854	51,780	103,560	414,240
CPE-52/CP-52	52	9,300	99,220	198,440	793,760
V-71	71	2,456	26,200	52,400	459,600
V-72	72	10,404	111,000	222,000	888,000
V-73	73	50,146	535,000	1,070,000	4,280,000
V-74	74	508,954	5,430,000	10,860,000	43,444,000

## APPENDIX C: ASTM Specifications

The following ASTM specifications describe the use of Brookfield Viscometers and accessories. Copies of these documents are available from Brookfield upon request.

C 965-96	Practices for Measuring Viscosity of Glass Above the Softening Point (Reapproved 2002)	D 2983-03	Test Method for Low-Temperature Viscosity of Automotive Fluid Lubricants Measured by the Brookfield Viscometer
C 1276-94	Standard Test Method for Measuring the Viscosity of Mold Powders Above their Melting Point Using a Rotational Viscometer	D 3232-88	Method for Measurement of Consistency of Lubricating Greases at High Temperatures
D 115-03	Methods of Testing Varnishes Used for Electrical Insulation	D 3236-88	Test Method for Apparent Viscosity of Hot Melt Adhesives and Coating Materials (Reapproved 1999)
D 562-81	Standard Test Method for Consistency of Paints Using the Stormer Viscometer	D 3468-99	Standard Specification for Liquid-Applied Neoprene and Chlorosulfonated Polyethylene Used in Roofing and Waterproofing
D 789-91	Test Methods for Determination of Relative Viscosity, Melting Point, and Moisture Content of Polyamide (PA)	D 3716-99	Method of Testing Emulsion Polymers for Use in Floor Polishes
D 1076-88	Specification for Rubber-Concentrated, Ammonia Preserved, Creamed and Centrifuged Natural Latex	D 3791-90	Standard Practice for Evaluating the Effects of Heat on Asphalts
D 1084-97	Test Methods for Viscosity of Adhesives	D 4016-81	Test Method for Viscosity of Chemical Grouts by the Brookfield Viscometer (Laboratory Method)
D 1417-90	Methods of Testing Rubber Latices-Synthetic	D 4287-94	Standard Test Method for High-Shear Viscosity Using the ICI Cone/Plate Viscometer
D 1439-83a	Methods of Testing Sodium Carboxymethyl-cellulose	D 4402-87	Standard Method for Viscosity Determinations of Unfilled Asphalts Using the Brookfield Thermosel Apparatus
D 1824-90	Test Method for Apparent Viscosity of Plastisols and Organosols at Low Shear Rates by Brookfield Viscometer	D 4889-93	Standard Test Methods for Polyurethane Raw Materials: Determination of Viscosity of Crude or Modified Isocyanates
D 2196-86	Test Methods for Rheological Properties on Non-Newtonian Materials by Rotational (Brookfield) Viscometer	D 5018-89	Standard Test Method for Shear Viscosity of Coal-Tar and Petroleum Pitches (Reapproved 1999)
D 2364-85	Standard Methods of Testing Hydroxyethyl-cellulose	D 5133-01	Standard Test Method for Low Temperature, Low Shear Rate, Viscosity/Temperature Dependence of Lubricating Oils Using a Temperature-Scanning Technique
D 2393-86	Test Method for Viscosity of Epoxy Resins and Related Components		
D 2556-97	Test Method for Apparent Viscosity of Adhesives Having Shear Rate Dependent Flow Properties		
D 2669-87	Test Method for Apparent Viscosity of Petroleum Waxes Compounded With Additives (Hot Melts)		

## APPENDIX D: References

### References

The following publications are available from the publishers listed for further reading on the subject of rheology and viscosity measurement:

NON-NEWTONIAN FLOW AND HEAT  
TRANSFER  
A.H.P. Skelland  
John Wiley & Sons, New York, NY.

PAINT FLOW AND PIGMENT DISPERSION  
Second Edition  
Temple C. Patton  
Interscience Publishers, New York, NY.

PRINCIPLES AND APPLICATIONS OF  
RHEOLOGY  
Arnold G. Fredrickson  
Prentice-Hall Inc., Englewood Cliffs, NJ.

RHEOLOGICAL METHODS IN FOOD  
PROCESS ENGINEERING  
James F. Steffe  
Freeman Press, E. Lansing, MI

RHEOLOGICAL PROPERTIES OF  
COSMETICS AND TOILETRIES  
Dennis Laba  
Marcel Dekker, Inc., New York, NY

RHEOLOGY FOR CERAMISTS  
Dennis R. Dinger  
Dinger Ceramic Consulting Services,  
Clemson, SC

VISCOMETRIC FLOWS OF NON-NEWTONIAN  
FLUIDS  
Coleman/Markovitz/Noll  
Springer-Verlag New York Inc., New York, NY.

VISCOSITY AND FLOW MEASUREMENT  
Van Wazer/Lyons/Kim/Colwell  
Interscience Publishers, New York, NY.

ISO standards may be purchased in the United  
States from:

American National Standards Institute  
11 West 42nd Street, New York, NY. 10036  
Phone: 212-642-4900; Fax: 212-302-1286

Outside the United States, please contact ISO's  
member in your country or:

International Organization for Standardization  
1 rue de Varembe, 1211 Geneva 20, Switzerland

ASTM test methods are available from:

ASTM  
1916 Race Street, Philadelphia, PA.  
Phone: 215-299-5400; Fax: 215-977-9679

Brookfield Engineering Laboratories maintains a library of technical papers on viscosity measurement and control. Reprints are available upon request at no charge. A current listing of available papers and an order form are provided in the booklet, TECHNICAL PAPERS ON VISCOSITY MEASUREMENT AND CONTROL (DATA LIST 091-C).

## **APPENDIX E: Brookfield Locations**

### **United States**

Brookfield Engineering Laboratories, Inc.  
11 Commerce Boulevard  
Middleboro, MA 02346

Tel: 508-946-6200 or 800-628-8139  
Fax: 508-946-6262  
e-mail: sales@brookfieldengineering.com

### **United Kingdom**

Brookfield Viscometers Limited  
1 Whitehall Estate  
Flex Meadow, Pinnacles West  
Harlow, Essex CM19 5TJ, England

Tel.: (44) 1279/451774 Fax: (44) 1279/451775  
e-mail: sales@brookfield.co.uk

### **Germany**

Brookfield Engineering Labs. Vertriebs GmbH  
Hauptstrasse 18  
D-73547 Lorch, Germany

Tel.: (49) 7172/927100 Fax: (49) 7172/927105  
e-mail: info@brookfield-gmbh.de



ISO 9001 Certified

**BROOKFIELD**

11 Commerce Blvd., Middleboro, MA 02346 USA  
T: 508-946-6200 or 800-628-8139 (USA only)  
F: 508-946-6262 W: [www.brookfieldengineering.com](http://www.brookfieldengineering.com)

Boston • Chicago • London • Stuttgart • Guangzhou