

BROOKFIELD KU-1+ VISCOMETER

Operating Instructions

Manual No. **M/97-241-B1101**



SPECIALISTS IN THE
MEASUREMENT AND
CONTROL OF VISCOSITY

BROOKFIELD ENGINEERING LABORATORIES, INC.
11 Commerce Boulevard, Middleboro, MA 02346-1031 USA

TEL 800-628-8139 or 508-946-6200 FAX 508-946-6262
www.brookfieldengineering.com

TABLE OF CONTENTS

I. INTRODUCTION	3
I.1 Components	3
I.2 Options	4
I.3 Viscometer Specifications	4
I.4 Can Specifications	5
I.5 Utilities	5
I.6 Printer Connection	5
II. OPERATION	6
II.1 Set-Up	6
II.2 Taking Measurements	6
II.3 Troubleshooting	7
Appendix A - KU-1+ Calibration Information	8
Appendix B - References	12
Appendix C - Warranty Repair and Service	13

I. INTRODUCTION

The Brookfield KU-1+ Viscometer measures fluid viscosity in Krebs units. The digital display of the Viscometer shows viscosity in Krebs Units (KU) or in the associated grams value (gm). A paddle type spindle is driven at 200 rpm by a constant speed motor. The reaction torque of the spindle rotating at 200 rpm is converted to viscosity in Krebs Units. The Viscometer will measure viscosity from 40 KU to 141 KU, at weights from 32 to 1,099 grams. Application reference information can be found in ASTM-D562.

I.1 Components

The KU-1+ Viscometer package (Figure 1 and Figure 1.1) includes:

- | | |
|--|---|
| (1) KU-1+ Viscometer, upright rod and base | (1) U.S. pint can (KU1-34) - not shown |
| (1) Paddle spindle (KU1-10) | (1) Power Cord, 115 VAC (DVP-65) or
220 VAC (DVP-66) |
| (1) US 1/2 pint can adapter (KU1-73) | (1) Operating instructions (M/97-241) |
| (1) US pint can adapter (KU1-74) | |

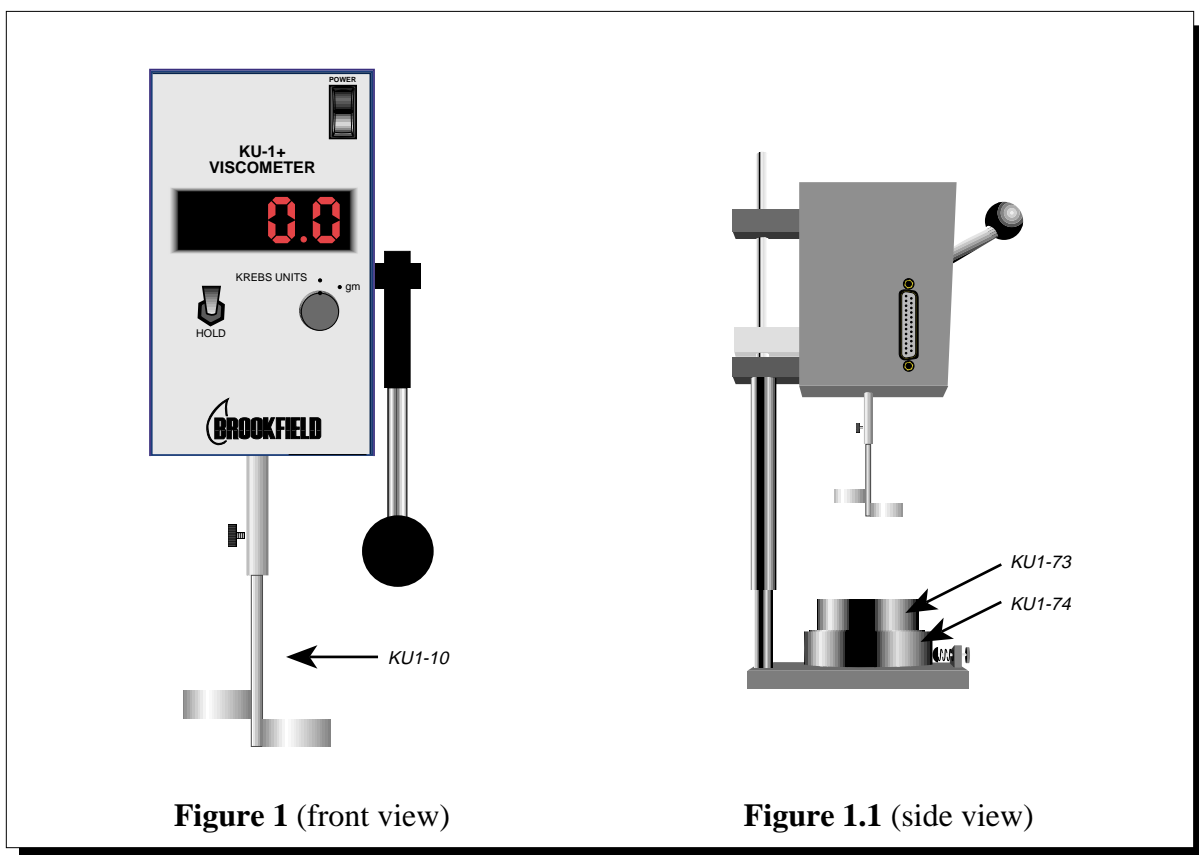

Please check to be sure that you have received all components, and that there is no damage. If you are missing any parts, please notify Brookfield or your local Brookfield agent immediately. Any shipping damage must be reported to the carrier.

I.2 Options

I.2.1 Air Purge

The air purge option (Brookfield Part No. KU-1A) allows the interior of the KU-1+ to be pressurized with air (or an inert gas) when the instrument is to be used in a hazardous environment (Figure 2). A built-in pressure switch turns the instrument off when the pressure drops below 2.0 PSI (falling). The switch comes on at 10.0 PSI (rising).

Connect a regulated clean air supply which is non-corrosive to brass to the fitting shown in Figure 2. Adjust the pressure to approximately 25 PSI.

Note: The pressure switch range is 0-40 PSI.

DO NOT CONNECT PRESSURE HIGHER THAN 40 PSI TO THE SWITCH!

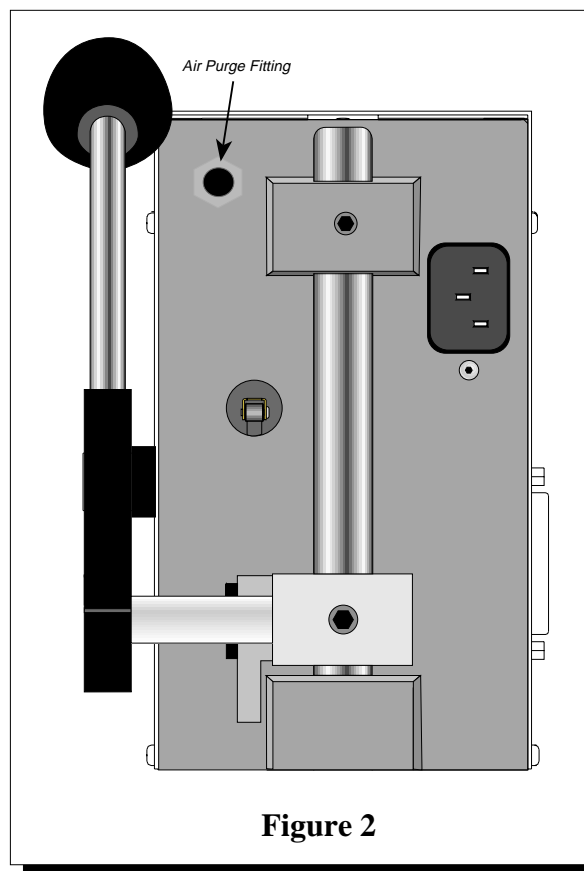

Figure 2

I.2.2 Optional Paste Spindle

The paste spindle, Part No. KU1-75Y, (Figure 3) is a special spindle; it is not included in a normal shipment/order. The design consists of offset rod-type vanes, approximately 2 mm diameter x 19 mm long. This spindle is suitable for use with high consistency materials such as roller mill pastes. *Do not use this spindle to report normal Krebs Unit measurements.* Record the grams value shown in the digital display and note that the paste spindle was used to make the viscosity measurement.

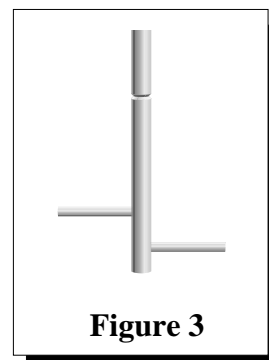

Figure 3

I.3 Viscometer Specifications

Range:	40–141 KU 32–1,099 gm
Accuracy:	± 1% of full scale range
Repeatability:	± 0.5% of full scale range
Paddle speed:	200 rpm ± 0.1 rpm
Printer output:	25D-Type Centronics Parallel Printer Output
Net weight:	22 lb. (10 kg)
Gross weight:	25 lb. (11 kg)
Dimensions:	15 x 11 x 20
Ambient conditions:	-20°C (-4°F) to 65°C (149°F)

I.4 Can Specifications

Container Dimensions

	<u>Can Height</u>	<u>Bottom Flange Diameter</u>
U.S. Pint	3.850" (9.78 cm)	3.385" (8.60 cm)
U.S. Half Pint	2.850" (7.24 cm)	2.875" (7.30 cm)
U.S. Quart	4.845" (12.31 cm)	4.230" (10.74 cm)

If you have a requirement for container dimensions other than those listed above, please contact Brookfield or an authorized Brookfield agent.

I.5 Utilities

Input voltage: 115 VAC or 230 VAC
 Input frequency: 50/60 Hz
 Power consumption: 20 watts
 Power cord color code:

	<i>USA</i>	<i>Outside USA</i>
Hot (live)	Black	Brown
Neutral	White	Blue
Ground (earth)	Green	Green/Yellow

I.6 Printer Connection

The KU-1+ is equipped with a parallel printer port located on the side of the instrument allowing printing with a parallel printer. A standard parallel printer cable (25 pin, Type D Centronics, available from Brookfield as part number CAP-86) is used to connect the viscometer to the printer.

When connected to a printer, the KU-1+ will print one line of data each time the "Hold Reading" switch is moved to the down position.

The data line includes the viscosity (in Krebs Units) and the associated weight (in grams):

715g 125.9KU

Dashes in the printout indicate an "over-range"

condition or that the handle has risen to the top position (i.e. the spindle is not rotating):

---- g ---- - KU

PARALLEL PRINTER OUTPUT CONNECTION

Pin	Function
1	STB
2	D0
3	D1
4	D2
5	D3
6	D4
7	D5
8	D6
9	D7
25	GND

Figure 4

Note: When connecting the cable to the KU-1+, THE PRINTER POWER (AC mains) SHOULD BE "OFF"!

II. OPERATION

II.1 Set-Up

- 1) Be sure that the power switch is off. Attach the power cord to the appropriate power source.
- 2) Move the operating handle to the top (upper most) position.
- 3) Connect the printer (if used) to the parallel port. Be sure the printer power is off.
- 4) Loosen the thumb screw on the Viscometer shaft; insert the paddle spindle into the Viscometer shaft, as far as it will go. Line up the groove on the spindle with the hole that the thumb screw goes into. Tighten the thumb screw.
- 5) **For Quart Cans:** The can will be placed directly on the viscometer base.
- 6) **For Pint Cans:** Place the pint can adapter (KU1-74) on the viscometer base, pulling the spring loaded front locator out and placing the adapter against the rear locating pins. Release the locator to secure the adapter in place.
- 7) **For 1/2 Pint Cans:** Follow the procedure for pint cans. Place the 1/2 pint can adapter (KU1-73) on top of the pint can adapter (KU1-74).

II.2 Taking Measurements

- 1) Pour sample into the container. Fill to 3/4 inch (20 mm) of the container lip.
- 2) Bring the sample in the container to the specified temperature.
- 3) Switch on the KU-1+ power switch and then the printer (if used). Switch the Hold Reading Switch to the up position. (See Figure 5.)
- 4) Select the desired display (KU or gm) using the Display unit Selector switch.
- 5) **For Quart Cans:** Place the sample container on the Viscometer base by pulling the spring loaded front locator out, placing the container against the rear of the locating pins, and releasing the locator to secure the can in place.
- 6) **For Pint & 1/2 Pint Cans:** Place the sample container directly on the can adapter mounted on the viscometer base.
- 7) Move the Viscometer handle down to the lowest position. This will automatically immerse the spindle into the fluid. If the correct amount of fluid



Figure 5

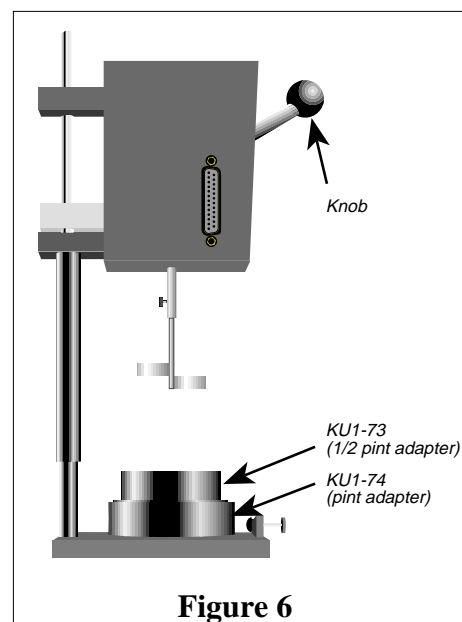

Figure 6

has been put into the container, the surface of the fluid will be at the immersion mark of the spindle.

CAUTION: When using the 1/2 pint can, do not lower the spindle directly into the container. The narrow diameter of the can requires the spindle to be introduced at an angle. Tilt the 1/2 pint can while lowering the viscometer.

8) The spindle will begin to rotate once the handle is within 1/2 inch of the lowest position.

9) Wait 5 seconds for the display reading to stabilize. A display of "----" indicates an over-range condition. If a printer is being used, these dashes will print in place of KU and gm data (Figure 7).

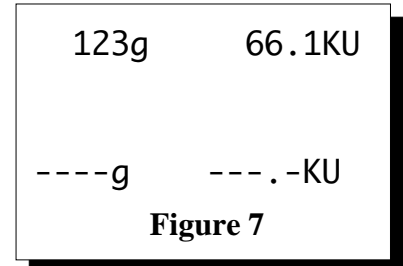

10) Move the Hold Reading Switch to the down position to "Hold" the display. If a printer is connected, a string of data will print as soon as the Hold reading switch is moved to the down position (Figure 7).

11) Raise the handle to the top position. This stops the spindle from rotating.

Note: When using 1/2 pint cans, you must lift the can and then tilt slightly to remove the spindle.

12) Loosen the thumb screw and remove spindle for cleaning.

Note: Do not remove the thumb screw. If dropped, it may fall into the sample.

II.3 Troubleshooting

If the operating handle is in the DOWN position and the display locks up and/or the spindle does not rotate the following should be checked:

- Be sure the **HOLD** switch is in the **UP** position. If the hold switch was in the DOWN position prior to engaging the operating handle, dashes (—) or the previous reading may appear in the display.
- The KU-1+ requires a shutdown (power off) period of at least 15 seconds before it can be operated properly. If the unit had previously been turned off and immediately turned back on (without a 30 second shutdown period) both the display and rotation may temporarily lock up.

If you experience these problems, simply raise the operating handle, turn the unit off and wait a minimum of 30 seconds before turning the power back on.

Appendix A - KU-1+ Calibration Information

The accuracy of the KU-1+ is verified using viscosity standard fluids which are available from Brookfield Engineering Laboratories or your local Brookfield dealer/distributor/representative. Viscosity Standards are calibrated at 25°C. Available standards are listed in Table A1 below:

<u>Brookfield Viscosity Standard</u>	<u>Nominal Viscosity (KU)</u>	<u>Temperature (°C)</u>
KU64	64	25
KU79	79	25
KU84	84	25
KU95	95	25
KU106	106	25

Brookfield Viscosity Standards

We recommend that Brookfield Viscosity Standard Fluids be replaced on an annual basis, one year from the date of initial use. These fluids can be stored under normal laboratory conditions. Disposal should be in accordance with local, state and federal regulations. Material Safety Data Sheets are available upon request.

Calibration Check Procedure

The frequency of the calibration check should be based on your company's standard practice for test and calibration of instruments.

- 1) Select any two viscosity standards listed in Table A1 to perform your calibration check. The viscosity standards are very temperature sensitive. The viscosity value of the fluid will change with temperature so it is important to control the temperature to 25.0°C.
- 2) Pour the selected fluid into a standard US 1-pint can. The spindle and the fluid in the can should come to temperature equilibrium before proceeding with the calibration check.

It is important that the fluid and the spindle come to 25.0°C, ±0.1°C, before proceeding with the calibration check.

- 3) Once the fluid and spindle have come to thermal equilibrium, place the sample container on the viscometer base, using the KU1-74 adapter. Switch the power switch and printer (if used) to "ON". Switch the Hold Reading Switch to the "UP" position. Turn the Select knob to "KU".
- 4) Move the viscometer handle down to the lowest position. The spindle will begin rotating once the handle is within 1/2 inch of the lowest position.
- 5) Wait five (5) seconds for the reading to stabilize. Switch the Hold Reading Switch to the "DOWN" position. **You will need to record measurements in KU and grams.** These two values work together to let you interpret the calibration results.

- 6) After you have recorded results in KU, then move the Selector knob to the "gm" position and record your reading in grams. If you are using a printer, both measurements will be sent to the printer and will print out as soon as the Hold Display switch is switched back to the DOWN position.

Interpretation of Calibration Check Results

When verifying the calibration of the KU-1+, the instrument tolerance and viscosity standard fluid tolerance must be **combined** to calculate the total allowable error.

The KU-1+ is accurate to ± 11 grams, which is 1% of the full scale range in grams. The Brookfield Viscosity Standard is accurate to $\pm 1\%$ of the stated viscosity in KU.

The total allowable error should be stated in KU. Since the instrument accuracy is stated in grams, you will have to use the comparison table (Table A2) and convert from grams to KU.

Correct interpretation of your calibration results requires that you compare your readings in grams to the equivalent in KU. You must then bracket your reading with upper and lower limits based on the allowable error of ± 11.0 grams. Convert this acceptable range in grams (as defined by the upper and lower limits) to KU units.

Example: Calculate the allowable error of the KU-1+ using fluid KU106; the stated viscosity of the fluid is 104.8 KU. The viscometer indicated a measured viscosity of 105 KU and 410 grams.

- 1) Measured results from the calibration check in grams were 410 grams. Locate 410 grams on the conversion chart (Table A2).
- 2) The KU-1+ is accurate to ± 11.0 grams. Starting from 410 grams, count 11 places above and below the 410 grams. This is called "bracketing" the acceptable range. In this case, the acceptable range will be from 399 grams to 421 grams.
- 3) Convert the acceptable range in grams to KU. Locate the minimum and maximum grams bracketed. Look to the right of each number for the conversion to KU. In this case, it will be 103.9 KU minimum and 105.7 KU maximum. The total difference between 103.9 and 105.7 KU is 1.8 KU. Therefore, the accuracy is ± 0.9 KU. ***This is the accuracy for the Viscometer in KU, ± 0.9 KU.***
- 4) Now that you have the accuracy for the instrument, you can add it to the accuracy of the fluid. The fluid is accurate to $\pm 1\%$ of the stated value in KU. The viscosity standard is calibrated at 104.8 KU, $\pm 1\%$ is equal to ± 1.0 KU.

$$\begin{array}{r} 0.9 \text{ KU (instrument accuracy)} \\ + \underline{1.0 \text{ KU (fluid accuracy)}} \\ \hline 1.9 \text{ KU (total allowable error)} \end{array}$$

- 5) Total allowable error for the calibration check in this example is 104.8 KU, ± 1.9 KU (102.9 KU to 106.7 KU). Since the measured reading of 105 KU falls within this range, the Viscometer is considered in calibration.

Table A2

Gram KU	Gram KU	Gram KU	Gram KU	Gram KU	Gram KU	Gram KU	Gram KU
	100 60.6	170 76.0	240 87.6	310 95.9	380 102.4	450 108.0	520 113.6
	101 60.9	171 76.2	241 87.8	311 96.0	381 102.5	451 108.1	521 113.7
32 40.2	102 61.1	172 76.4	242 87.9	312 96.1	382 102.6	452 108.2	522 113.8
33 40.6	103 61.4	173 76.6	243 88.0	313 96.2	383 102.6	453 108.2	523 113.8
34 40.9	104 61.6	174 76.8	244 88.2	314 96.3	384 102.7	454 108.3	524 113.9
35 41.3	105 61.9	175 77.0	245 88.3	315 96.4	385 102.8	455 108.4	525 114.0
36 41.6	106 62.1	176 77.2	246 88.4	316 96.5	386 102.9	456 108.5	526 114.1
37 42.0	107 62.4	177 77.4	247 88.6	317 96.7	387 103.0	457 108.6	527 114.2
38 42.3	108 62.6	178 77.6	248 88.7	318 96.8	388 103.0	458 108.6	528 114.2
39 42.6	109 62.8	179 77.8	249 88.8	319 96.9	389 103.1	459 108.7	529 114.3
40 43.0	110 63.1	180 78.0	250 88.9	320 97.0	390 103.2	460 108.8	530 114.4
41 43.3	111 63.3	181 78.2	251 89.1	321 97.1	391 103.3	461 108.9	531 114.5
42 43.6	112 63.6	182 78.4	252 89.2	322 97.2	392 103.4	462 109.0	532 114.6
43 44.0	113 63.8	183 78.6	253 89.3	323 97.3	393 103.4	463 109.0	533 114.6
44 44.3	114 64.0	184 78.8	254 89.4	324 97.4	394 103.5	464 109.1	534 114.7
45 44.6	115 64.3	185 79.0	255 89.6	325 97.5	395 103.6	465 109.2	535 114.8
46 45.0	116 64.5	186 79.1	256 89.7	326 97.6	396 103.7	466 109.3	536 114.9
47 45.3	117 64.7	187 79.3	257 89.8	327 97.7	397 103.8	467 109.4	537 115.0
48 45.6	118 65.0	188 79.5	258 89.9	328 97.8	398 103.8	468 109.4	538 115.0
49 45.9	119 65.2	189 79.7	259 90.1	329 97.9	399 103.9	469 109.5	539 115.1
50 46.3	120 65.4	190 79.9	260 90.2	330 98.0	400 104.0	470 109.6	540 115.2
51 46.6	121 65.7	191 80.1	261 90.3	331 98.1	401 104.1	471 109.7	541 115.3
52 46.9	122 65.9	192 80.3	262 90.4	332 98.2	402 104.2	472 109.8	542 115.4
53 47.2	123 66.1	193 80.4	263 90.6	333 98.3	403 104.2	473 109.8	543 115.4
54 47.5	124 66.3	194 80.6	264 90.7	334 98.4	404 104.3	474 109.9	544 115.5
55 47.9	125 66.6	195 80.8	265 90.8	335 98.5	405 104.4	475 110.0	545 115.6
56 48.2	126 66.8	196 81.0	266 90.9	336 98.6	406 104.5	476 110.1	546 115.7
57 48.5	127 67.0	197 81.2	267 91.0	337 98.7	407 104.6	477 110.2	547 115.8
58 48.8	128 67.2	198 81.3	268 91.2	338 98.8	408 104.6	478 110.2	548 115.8
59 49.1	129 67.5	199 81.5	269 91.3	339 98.9	409 104.7	479 110.3	549 115.9
60 49.4	130 67.7	200 81.7	270 91.4	340 99.0	410 104.8	480 110.4	550 116.0
61 49.7	131 67.9	201 81.8	271 91.5	341 99.1	411 104.9	481 110.5	551 116.1
62 50.0	132 68.1	202 82.0	272 91.6	342 99.2	412 105.0	482 110.6	552 116.2
63 50.3	133 68.4	203 82.2	273 91.8	343 99.3	413 105.0	483 110.6	553 116.2
64 50.6	134 68.6	204 82.3	274 91.9	344 99.4	414 105.1	484 110.7	554 116.3
65 50.9	135 68.8	205 82.5	275 92.0	345 99.4	415 105.2	485 110.8	555 116.4
66 51.2	136 69.0	206 82.7	276 92.1	346 99.5	416 105.3	486 110.9	556 116.5
67 51.5	137 69.2	207 82.8	277 92.2	347 99.6	417 105.4	487 111.0	557 116.6
68 51.8	138 69.5	208 83.0	278 92.3	348 99.7	418 105.4	488 111.0	558 116.6
69 52.1	139 69.7	209 83.2	279 92.5	349 99.8	419 105.5	489 111.1	559 116.7
70 52.4	140 69.9	210 83.3	280 92.6	350 99.9	420 105.6	490 111.2	560 116.8
71 52.7	141 70.1	211 83.5	281 92.7	351 100.0	421 105.7	491 111.3	561 116.9
72 53.0	142 70.3	212 83.6	282 92.8	352 100.1	422 105.8	492 111.4	562 117.0
73 53.3	143 70.5	213 83.8	283 92.9	353 100.2	423 105.8	493 111.4	563 117.0
74 53.6	144 70.7	214 84.0	284 93.0	354 100.3	424 105.9	494 111.5	564 117.1
75 53.9	145 71.0	215 84.1	285 93.2	355 100.3	425 106.0	495 111.6	565 117.2
76 54.2	146 71.2	216 84.3	286 93.3	356 100.4	426 106.1	496 111.7	566 117.3
77 54.5	147 71.4	217 84.4	287 93.4	357 100.5	427 106.2	497 111.8	567 117.4
78 54.8	148 71.6	218 84.5	288 93.5	358 100.6	428 106.2	498 111.8	568 117.4
79 55.0	149 71.8	219 84.7	289 93.6	359 100.7	429 106.3	499 111.9	569 117.5
80 55.3	150 72.0	220 84.8	290 93.7	360 100.8	430 106.4	500 112.0	570 117.6
81 55.6	151 72.2	221 85.0	291 93.8	361 100.9	431 106.5	501 112.1	571 117.7
82 55.9	152 72.4	222 85.1	292 94.0	362 101.0	432 106.6	502 112.2	572 117.7
83 56.2	153 72.6	223 85.3	293 94.1	363 101.0	433 106.6	503 112.2	573 117.8
84 56.5	154 72.8	224 85.4	294 94.2	364 101.1	434 106.7	504 112.3	574 117.9
85 56.7	155 73.0	225 85.6	295 94.3	365 101.2	435 106.8	505 112.4	575 117.9
86 57.0	156 73.2	226 85.7	296 94.4	366 101.3	436 106.9	506 112.5	576 118.0
87 57.3	157 73.4	227 85.9	297 94.5	367 101.4	437 107.0	507 112.6	577 118.1
88 57.6	158 73.6	228 86.0	298 94.6	368 101.4	438 107.0	508 112.6	578 118.2
89 57.8	159 73.8	229 86.1	299 94.7	369 101.5	439 107.1	509 112.7	579 118.2
90 58.1	160 74.0	230 86.3	300 94.8	370 101.6	440 107.2	510 112.8	580 118.3
91 58.4	161 74.2	231 86.4	301 95.0	371 101.7	441 107.3	511 112.9	581 118.4
92 58.6	162 74.4	232 86.6	302 95.1	372 101.8	442 107.4	512 113.0	582 118.4
93 58.9	163 74.6	233 86.7	303 95.2	373 101.8	443 107.4	513 113.0	583 118.5
94 59.1	164 74.8	234 86.8	304 95.3	374 101.9	444 107.5	514 113.1	584 118.6
95 59.4	165 75.0	235 87.0	305 95.4	375 102.0	445 107.6	515 113.2	585 118.6
96 59.6	166 75.2	236 87.1	306 95.5	376 102.1	446 107.7	516 113.3	586 118.7
97 59.9	167 75.4	237 87.2	307 95.6	377 102.2	447 107.8	517 113.4	587 118.8
98 60.1	168 75.6	238 87.4	308 95.7	378 102.2	448 107.8	518 113.4	588 118.8
99 60.4	169 75.8	239 87.5	309 95.8	379 102.3	449 107.9	519 113.5	589 118.9

Table A2 (continued)

Gram	KU	Gram	KU	Gram	KU	Gram	KU	Gram	KU	Gram	KU	Gram	KU
590	119.0	660	122.8	730	126.8	800	131.2	870	134.7	940	137.6	1010	139.9
591	119.0	661	122.8	731	126.9	801	131.2	871	134.8	941	137.6	1011	139.9
592	119.1	662	122.9	732	126.9	802	131.3	872	134.8	942	137.7	1012	140.0
593	119.2	663	122.9	733	127.0	803	131.3	873	134.9	943	137.7	1013	140.0
594	119.2	664	123.0	734	127.0	804	131.4	874	134.9	944	137.8	1014	140.0
595	119.3	665	123.0	735	127.1	805	131.4	875	134.9	945	137.8	1015	140.0
596	119.4	666	123.1	736	127.2	806	131.5	876	135.0	946	137.8	1016	140.0
597	119.4	667	123.1	737	127.2	807	131.6	877	135.0	947	137.9	1017	140.0
598	119.5	668	123.2	738	127.3	808	131.6	878	135.1	948	137.9	1018	140.0
599	119.5	669	123.2	739	127.3	809	131.7	879	135.1	949	138.0	1019	140.1
600	119.6	670	123.3	740	127.4	810	131.7	880	135.2	950	138.0	1020	140.1
601	119.7	671	123.3	741	127.5	811	131.8	881	135.2	951	138.0	1021	140.1
602	119.7	672	123.4	742	127.5	812	131.8	882	135.3	952	138.1	1022	140.1
603	119.8	673	123.4	743	127.6	813	131.9	883	135.3	953	138.1	1023	140.1
604	119.8	674	123.5	744	127.6	814	131.9	884	135.4	954	138.2	1024	140.1
605	119.9	675	123.6	745	127.7	815	132.0	885	135.4	955	138.2	1025	140.1
606	120.0	676	123.6	746	127.8	816	132.0	886	135.4	956	138.2	1026	140.2
607	120.0	677	123.7	747	127.8	817	132.1	887	135.5	957	138.3	1027	140.2
608	120.1	678	123.7	748	127.9	818	132.1	888	135.5	958	138.3	1028	140.2
609	120.1	679	123.8	749	128.0	819	132.2	889	135.6	959	138.4	1029	140.2
610	120.2	680	123.8	750	128.0	820	132.2	890	135.6	960	138.4	1030	140.2
611	120.2	681	123.9	751	128.1	821	132.3	891	135.6	961	138.4	1031	140.2
612	120.3	682	123.9	752	128.2	822	132.3	892	135.7	962	138.5	1032	140.2
613	120.3	683	124.0	753	128.2	823	132.4	893	135.7	963	138.5	1033	140.3
614	120.4	684	124.0	754	128.3	824	132.4	894	135.8	964	138.6	1034	140.3
615	120.4	685	124.1	755	128.4	825	132.5	895	135.8	965	138.6	1035	140.3
616	120.5	686	124.2	756	128.4	826	132.6	896	135.8	966	138.6	1036	140.3
617	120.6	687	124.2	757	128.5	827	132.6	897	135.9	967	138.7	1037	140.3
618	120.6	688	124.3	758	128.6	828	132.7	898	135.9	968	138.7	1038	140.4
619	120.7	689	124.3	759	128.6	829	132.7	899	136.0	969	138.8	1039	140.4
620	120.7	690	124.4	760	128.7	830	132.8	900	136.0	970	138.8	1040	140.4
621	120.8	691	124.5	761	128.7	831	132.8	901	136.1	971	138.8	1041	140.4
622	120.8	692	124.5	762	128.8	832	132.9	902	136.1	972	138.9	1042	140.4
623	120.9	693	124.6	763	128.9	833	132.9	903	136.2	973	138.9	1043	140.5
624	120.9	694	124.6	764	128.9	834	133.0	904	136.2	974	139.0	1044	140.5
625	121.0	695	124.7	765	129.0	835	133.0	905	136.2	975	139.0	1045	140.5
626	121.0	696	124.8	766	129.1	836	133.0	906	136.2	976	139.0	1046	140.5
627	121.1	697	124.8	767	129.1	837	133.1	907	136.3	977	139.1	1047	140.5
628	121.1	698	124.9	768	129.2	838	133.1	908	136.3	978	139.1	1048	140.6
629	121.2	699	124.9	769	129.3	839	133.2	909	136.4	979	139.1	1049	140.6
630	121.2	700	125.0	770	129.3	840	133.2	910	136.4	980	139.2	1050	140.6
631	121.3	701	125.1	771	129.4	841	133.3	911	136.4	981	139.2	1051	140.6
632	121.3	702	125.1	772	129.5	842	133.3	912	136.5	982	139.2	1052	140.6
633	121.4	703	125.2	773	129.5	843	133.4	913	136.5	983	139.3	1053	140.7
634	121.4	704	125.2	774	129.6	844	133.4	914	136.6	984	139.3	1054	140.7
635	121.5	705	125.3	775	129.7	845	133.5	915	136.6	985	139.3	1055	140.7
636	121.6	706	125.4	776	129.7	846	133.6	916	136.6	986	139.4	1056	140.7
637	121.6	707	125.4	777	129.8	847	133.6	917	136.7	987	139.4	1057	140.7
638	121.7	708	125.5	778	129.8	848	133.7	918	136.7	988	139.4	1058	140.7
639	121.7	709	125.5	779	129.9	849	133.7	919	136.8	989	139.5	1059	140.8
640	121.8	710	125.6	780	130.0	850	133.8	920	136.8	990	139.5	1060	140.8
641	121.8	711	125.7	781	130.0	851	133.8	921	136.8	991	139.5	1061	140.8
642	121.9	712	125.7	782	130.1	852	133.9	922	136.9	992	139.6	1062	140.8
643	121.9	713	125.8	783	130.2	853	133.9	923	136.9	993	139.6	1063	140.8
644	122.0	714	125.8	784	130.2	854	134.0	924	137.0	994	139.6	1064	140.8
645	122.0	715	125.9	785	130.3	855	134.0	925	137.0	995	139.6	1065	140.8
646	122.0	716	126.0	786	130.4	856	134.0	926	137.0	996	139.7	1066	140.9
647	122.1	717	126.0	787	130.4	857	134.1	927	137.1	997	139.7	1067	140.9
648	122.1	718	126.1	788	130.5	858	134.1	928	137.1	998	139.7	1068	140.9
649	122.2	719	126.1	789	130.5	859	134.2	929	137.2	999	139.7	1069	140.9
650	122.2	720	126.2	790	130.6	860	134.2	930	137.2	1000	139.8	1070	140.9
651	122.3	721	126.3	791	130.7	861	134.3	931	137.2	1001	139.8	1071	140.9
652	122.3	722	126.3	792	130.7	862	134.3	932	137.3	1002	139.8	1072	140.9
653	122.4	723	126.4	793	130.8	863	134.4	933	137.3	1003	139.8	1073	140.9
654	122.4	724	126.4	794	130.8	864	134.4	934	137.4	1004	139.8	1074	140.9
655	122.5	725	126.5	795	130.9	865	134.5	935	137.4	1005	139.9	1075	140.9
656	122.6	726	126.6	796	131.0	866	134.5	936	137.4	1006	139.9	1076	141.0
657	122.6	727	126.6	797	131.0	867	134.6	937	137.5	1007	139.9	1077	141.0
658	122.7	728	126.7	798	131.1	868	134.6	938	137.5	1008	139.9	1078	141.0
659	122.7	729	126.7	799	131.1	869	134.7	939	137.6	1009	139.9	1079	141.0

Appendix B - References

The KU-1+ Viscometer is compatible with:

ASTM D 562 Standard Test Method for Consistency of Paint Using the Stormer
Viscometer

Appendix C - Warranty Repair and Service

Warranty

Brookfield Viscometers are guaranteed for one year from date of purchase against defects in materials and workmanship. They are certified against primary viscosity standards traceable to the National Institute of Standards and Technology (NIST). The Viscometer must be returned to Brookfield Engineering Laboratories, Inc. or the Brookfield dealer from whom it was purchased for no charge warranty service. Transportation is at the purchaser's expense. The Viscometer should be shipped in its original container together with spindles originally provided with the instrument.

For repair or service in the **United States**, return to:

Brookfield Engineering Laboratories, Inc.

11 Commerce Boulevard.

Middleboro, MA 02346 U.S.A.

Telephone: 508-946-6200 FAX: 508-946-6262

email: service@brookfieldengineering.com

For repair or service **outside the United States**, consult **Brookfield Engineering Laboratories, Inc.** or the dealer from whom you purchased the instrument.

For repair or service in the **United Kingdom**, return to:

Brookfield Viscometers Limited

1 Whitehall Estate

Flex Meadow

Pinnacles West

Harlow, Essex CM19 5TJ, United Kingdom

Telephone: (44) 27/945 1774 FAX: (44) 27/945 1775

email: service@brookfield.co.uk

For repair or service in **Germany**, return to:

Brookfield Engineering Laboratories Vertriebs GmbH

Barbarossastrasse 3

D-73547 Lorch, Germany

Telephone: (49) 7172/927100 FAX: (49) 7172/927105

email: info@brookfield-gmbh.de